



MOTOROLA
test equipment

CODE SYNTHESIZER



R-1100A

R-1100A CODE SYNTHESIZER

CONTENTS

<i>SECTION</i>	<i>PAGE</i>
Foreword	iii,iv
Performance Specifications	v
Model Chart	v
1. DESCRIPTION	1
1.1 Introduction	1
1.2 Case	1
1.3 Display Circuit Board	1
1.4 Main Logic Circuit Board	1
1.5 Chassis	1
1.6 Accessories	1
2. OPERATING INSTRUCTIONS	2
2.1 Introduction	2
2.2 Indicators, Controls and Connectors	2
2.3 Applications	4
3. THEORY OF OPERATION	7
3.1 Introduction	7
3.2 User Interface	8
3.3 Frequency Generation	8
3.4 Digital-To-Analog Converter	8
3.5 Harmonic Filters	8
3.6 Audio Amplification	8
3.7 Audio Output For Entry Verification	8
3.8 Power Supply	8
4. MAINTENANCE	9
4.1 Routine Maintenance	9
4.2 Housing Removal	9
4.3 Calibration	9
4.4 Corrective Maintenance	10
4.5 Returning Equipment To Factory	11



MOTOROLA INC.
Communications Division

service publications

1301 E. Algonquin Road, Schaumburg, IL 60196

5. DIAGRAMS AND PARTS LIST	13
System Block Diagram	13
Power Supply Schematic	13
Circuit Board Detail	14
Schematic Waveforms	14
Schematic Diagram	15
Parts Location Detail	16
Parts Lists	16
6. SUPPLEMENTARY INFORMATION	17
Appendix - Commonly Used Signaling Tones And Codes	17,18
Safe Handling of CMOS Integrated Circuit Devices	68P81106E84

FOREWORD

1. SCOPE OF MANUAL

This manual is intended for use by experienced technicians familiar with similar types of equipment. It contains all service information required for the equipment described and is current as of the printing date. Changes which occur after the printing date are incorporated by Instruction Manual Revisions (SMR). These SMR's are added to the manuals as the engineering changes are incorporated into the equipment.

2. MODEL AND KIT IDENTIFICATION

Motorola equipments are specifically identified by an overall model number on the nameplate. In most cases, assemblies and kits which make up the equipment also have kit model numbers stamped on them. When a production or engineering change is incorporated, revision suffix numerals are added to the affected kit model number. For example, a TLN4448A becomes a TLN4448A-1 with the first revision, TLN4448A-2 with the second revision, etc.

As diagrams are updated, information about the change is incorporated into a revision column. This revision column appears in the manual next to the parts list or, in some cases, on the diagram. It lists the reference number, part number, and description of the parts removed or replaced when the suffix number changed. With this information, the technician can find the information for the current version, and any previous version, of the equipment covered by the manual.

3. SERVICE

Motorola's National Service Organization offers one of the finest nation-wide installation and maintenance programs available to communication equipment users. This organization includes approximately 800 authorized Motorola Service Stations (MSS) located throughout the United States, each manned by one or more trained, FCC licensed technicians.

These MSS's are independently owned and operated and were selected by Motorola to service its customers. Motorola maintenance is available on either a time and material basis or on a periodic fixed-fee type arrangement.

The administrative staff of this organization consists of national, area and district service managers and

district representatives, all of whom are Motorola employees with the objective to improve the service to our customers.

Should you wish to purchase a service contract for your Motorola equipment, contact your Motorola Service Representative, or write to:

National Service Manager
Motorola Communications Division
1303 E. Algonquin Road
Schaumburg, Illinois 60196

4. REPLACEMENT PARTS ORDERING

Motorola maintains a number of parts offices strategically-located throughout the United States. These facilities are staffed to process parts orders, identify part numbers, and otherwise assist in the maintenance and repair of Motorola Communications Division products.

Orders for all parts *except* crystals, active filters, code plugs, channel elements, and "Vibrasender"® and "Vibrasponder"® resonant reeds should be sent to the nearest area parts center. Orders for instruction manuals should also be sent to the area parts center.

When ordering replacement parts or equipment information, the complete identification number should be included. This applies to all components, kits, and chassis. If the component part number is not known, the order should include the number of the chassis or kit of which it is a part, and sufficient description of the desired component to identify it.

Orders for crystals, channel elements, active filters, code plugs, and reeds should be sent directly to the factory address listed on the following page. Crystal and channel element orders should specify the crystal or channel element type number, crystal and carrier frequency, and the chassis model number in which the part is used.

Orders for active filters, code plugs, "Vibrasender" and "Vibrasponder" resonant reeds should specify type number and frequency, and should identify the owner/operator of the communications system in which these items are to be used.

5. ADDRESSES

5.1 GENERAL OFFICES

MOTOROLA Communications and Electronics Inc.

Communications and Electronics Parts
1313 E. Algonquin Rd.,
Schaumburg, Illinois 60196
Phone: 312-576-3900

5.2 U.S. ORDERS

WESTERN AREA PARTS

1170 Chess Drive, Foster City,
San Mateo, California 94404
Phone: 415-349-3111
TWX: 910-375-3877

MIDWEST AREA PARTS

1313 E. Algonquin Road
Schaumburg, Ill. 60196
Phone: 312-576-7322
TWX: 910-693-0869

MID-ATLANTIC AREA PARTS

7230 Parkway Drive
Hanover, Maryland 20176
Phone: 301-796-8600
TWX: 710-862-1941

EAST CENTRAL AREA PARTS

12995 Snow Road,
Parma, Ohio 44130
Phone: 216-267-7322
TWX: 810-421-8845

EASTERN AREA PARTS

85 Harristown Road,
Glen Rock, New Jersey 07452
Phone: 201-447-4000
TWX: 710-988-5602

PACIFIC SOUTHWESTERN AREA PARTS

P.O. Box 85036
San Diego, California 92138
Phone: 714-578-2222
TWX: 910-335-1634

GULF STATES AREA PARTS

8550 Katy Freeway
Suite 128
Houston, Texas 77024
Phone: 713-932-8955

SOUTHWESTERN AREA PARTS

P.O. Box 34290
3320 Belt Line Road,
Dallas, Texas 75234
Phone: 214-241-2151
TWX: 910-860-5505

SOUTHEASTERN AREA PARTS

P.O. Box 368
Decatur, Georgia 30031
Phone: 504-981-9800
TWX: 810-766-0876

5.3 CANADIAN ORDERS

CANADIAN MOTOROLA ELECTRONICS COMPANY

National Parts Department
3125 Steeles Avenue,
East Willowdale, Ontario
Phone: 416-499-1441
TWX: 610-492-2713
Telex: 02-29944LD

5.4 ALL COUNTRIES EXCEPT U.S. AND CANADA

MOTOROLA, INC. OR MOTOROLA AMERICAS, INC.

International Parts Dept.
1313 E. Algonquin Road
Schaumburg, Illinois 60196 U.S.A.
Phone: 312-576-6492
TWX: 910-693-0869
Telex: 722443 or 722424
Cable: MOTOL PARTS

5.5 FACTORY ADDRESS FOR CRYSTAL, CHANNEL ELEMENT, ACTIVE FILTER, CODE PLUGS AND RESONANT REED ORDERS

ALL MAIL ORDERS

Motorola, Inc.
Component Products Sales & Service
P.O. Box 66191
O'Hare International Airport
Chicago, Ill. 60666

CORRESPONDENCE

Motorola, Inc.
Component Products Sales & Service
2553 N. Edgington Street
Franklin Park, Illinois 60131

PERFORMANCE SPECIFICATIONS

FREQUENCY RANGE	10 Hz to 9999 Hz
RESOLUTION	± 1 digit
DISTORTION	2% (3% dc operation)
ACCURACY (TEMP.)	0.01%
TIME INTERVAL RANGE	0 sec. to 999.9 sec.
RESOLUTION	± 1 digit
ACCURACY (TEMP.)	.005 sec.
OUTPUT AMPLITUDE	0-3 V rms, adjustable
OPERATING TEMP.	0°-50°
POWER	110/220 V ac, 50/60 Hz via internal power transformer tap or 12 V dc. Optional rechargeable battery and built-in charger available. Operating time on fully charged battery; 5 hours at room temperature of 25 °C. Battery may be recharged to over 95% of capacity in 12 hours also at 25 °C.
WEIGHT	Approx. 6 lbs. (2.72 kgm.) less optional battery and built-in charger. Add 4 lbs. (1.7 kgm.) for battery option.
SIZE	4-1/2" x 9" x 10-3/8" (11.4 cm x 22.9 cm x 26.4 cm) including handle and feet.

MOTOROLA

MODEL CHART

CODE:

- = QUANTITY OF ONE SUPPLIED
- * = INDICATES 220 V AC WIRING CHANGE ONLY WHICH IS DONE AT THE FACTORY.

ITEM	DESCRIPTION	MODEL NUMBER			
		R-1100A	R-1100AN	R-1100A/220	R-1100AN/220
RTL4049A	CHASSIS	X	X	X	X
RTL4050A	MAIN LOGIC BOARD	X	X	X	X
RTL4051A	DISPLAY BOARD	X	X	X	X
RTL4006A	BATTERY CASE	X	X	X	X

1. DESCRIPTION

1.1 INTRODUCTION

The Motorola R-1100A Code Synthesizer is an audio frequency signal generator. It generates continuous or pulse coded audio frequency signals used in testing tone controlled radios or tone coded radiotelephone systems. The code synthesizer generates signals to test "Private-Line", "Digital Private-Line", tone remote base stations and radiotelephone dialing systems. The generator is a compact solid-state test instrument assembled in a portable case.

1.2 CASE

The case of the code synthesizer is metal with a front panel bezel that has extended sides to protect panel controls. Four feet on the bottom of the case keep it from direct contact with the bench or work surface. Attached to the front two feet is a swing-out bar that raises the front of the case to provide easy viewing and data entry on the front panel keyboard. A handle is mounted on the side of the case for easy carrying. Overall, the code synthesizer has three principle sections. These sections are the display board, main logic board and chassis.

1.3 DISPLAY CIRCUIT BOARD

1.3.1 The RTL-4051A Display Circuit Board is subdivided into a front panel and printed circuit board which is mounted directly behind the front panel. The front panel is a graphic sheet with pressure sensitive switches. These switches are used for momentary contact data entry. Other mechanical switches on the front panel control permanent closures such as power and cycle. The front panel also has a BNC output jack and controls for setting audio output levels (0.0 to 3.0 V rms into 600 ohms) of tones A and B. The LED readouts and indicators are displayed on the front panel but are mounted on the printed circuit board behind the front panel. The keyboard on the front panel and the display printed circuit board are electrically interconnected through a ribbon cable.

1.3.2 All the LED readouts, indicator boards and multiplexing logic circuitry are mounted on the display printed circuit board. There are seven 7-segment LED readouts. These readouts give visual indication of frequencies, codes or times entered into the unit via the keyboard as well as frequencies and codes being generated by the unit.

1.3.3 Four smaller printed circuit boards are mounted on the display circuit board. These circuit boards mount LED indicators A1 through A4, which give visual indication of timing, mode and level selection. Also wired to the display circuit board is the ribbon cable connecting it to the main logic circuit board.

1.4 MAIN LOGIC CIRCUIT BOARD

The RTL-4050A Main Logic Circuit Board contains the firmware and hardware for generation and control of audio frequency tones. A Motorola MC3870 Microprocessor is programmed to multiplex front panel data entry and LED readout, verify data entry, generate audio frequency tones, and control mode selection. This board and the display board obtain operating voltages from the chassis power supply.

1.5 CHASSIS

The RTL-4049A Chassis Kit provides the metal framework for mounting the circuit boards, and front and rear panels. Components for the power supply are mounted on the rear panel. The code synthesizer is operated from 110 V ac, 50/60 Hz (220 V ac optional wiring) or 12 V dc. For 12 V dc operation, the power source is either internal (option RTP-1003A Battery Pack Kit) or external through a rear panel connection jack. Connecting the audio generator to an external dc source automatically disconnects the internal battery pack.

1.6 ACCESSORIES

The following accessory items are available for use with the R-1100A Code Synthesizer.

1.6.1 RTL-1003A 600 Ohm Transformer Kit

The RTL-1003A 600 Ohm Transformer Kit is used to match the R-1100A Code Synthesizer to a balanced 600-ohm load. The transformer kit consists of an RTL-4053A Matching Transformer and Dual Binding Post Adapter (Motorola Part Number 58-80336A27).

1.6.2 RTL-4052A Carrying Case

The RTL-4052A Carrying Case is used as a convenient means to transport the R-1100A Code Synthesizer. It is especially useful in portable operation of the instrument. This accessory consists of a case and shoulder strap.

1.6.3 Plug For External 12 V DC Jack

When external 12 V dc is used to power the code synthesizer, it requires a special jack to plug into the rear panel of the instrument. The Motorola Part Number of the jack is 9-80334A25.

1.6.4 Plug For External Strobe Jack

A strobe input at the rear panel of the code synthesizer allows synchronous operation of two or more units. A special jack is required. The Motorola Part Number for the jack is 28-80334A22.

2. OPERATING INSTRUCTIONS

2.1 INTRODUCTION

All display indicators, controls and connectors used by the operator are located on the front and rear panels of the R-1100A Code Synthesizer. The following paragraphs describe each of these individually to explain their use or function. Afterwards, practical applications of the code synthesizer are described.

2.2 INDICATORS, CONTROLS AND CONNECTORS

2.2.1 Front Panel (See Figure 2-1)

The R-1100A Code Synthesizer front panel is a graphic sheet with pressure sensitive switches. Controls and mechanical switches for permanent closures also are mounted on the front panel. The following information describes each one.

- (1) Seven-Segment Display — gives a visual indication of frequencies, codes or times entered into the unit via the keyboard as well as frequencies, and codes being generated by the unit. Only four digits are used while in any of the Two-Tone signaling sequences, however, seven digits are used when in the TEL DL MODE.
- (2) POWER Switch — is three position - AC, OFF, and DC. The AC position is used to turn the unit on when operated from an ac power source. The DC position is used to turn the unit on when operated from a 12 V dc power source.
- (3) BNC Jack — provides an output connection for generated frequencies and codes. Specified output levels are measured when terminated into 600 ohms.
- (4) Tone "A" LEVEL Control — sets the tone "A" amplitude output at the BNC jack.
- (5) Tone "A" Indicator — turns on when the generator outputs tone A.
- (6) Tone "B" Indicator — turns on when the generator outputs tone B.
- (7) Tone "B" LEVEL Control — sets the tone "B" amplitude output at the BNC jack.
- (8) MODE — By means of the MODE up or down select switch, any one of seven modes is selected. Modes A or B provide single tone output, and Mode A/B provides a two-tone output. Modes DPL and DPL INVERT provide "Digital Private-Line" outputs. Mode TN REM provides a two-tone output which sequences from guard tone to function tone to low level guard tone (-30 dB). Mode TEL DL provides an IMTS or 2805 interrupt dialing sequence output to simulate terminal dialing.
- (9) MODE Up Select Switch — when pressed causes the MODE selected to advance upward.
- (10) MODE Down Select Switch — when pressed causes the MODE selected to advance downward.
- (11) Decimal Point — used to enter fractional numbers.
- (12) RESET — used to clear seven segment displays and to initialize data entry circuits.
- (13) B DELAY — enters program time delay which occurs after tone "B" output.

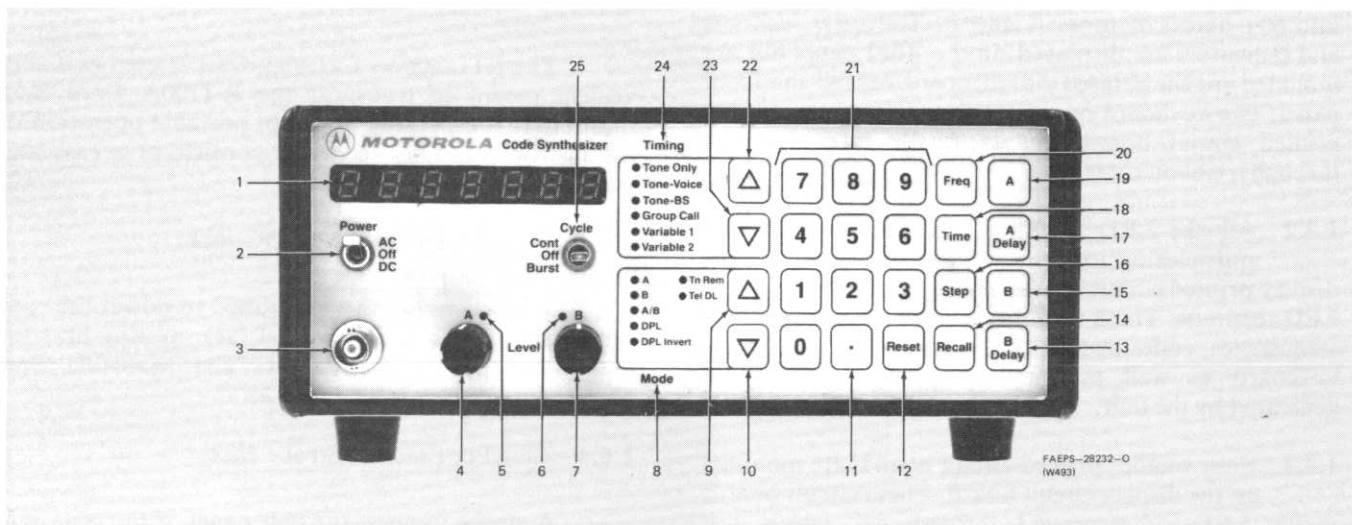

Figure 2-1. Location Of Front Panel Display Indicators, Controls and Connectors

(14) **RECALL** — used to review data which has been previously programmed by the user. Data to be reviewed is displayed when **RECALL** followed by selected data entry keys are pressed. For example, tone “A” frequency is displayed when **RECALL**, **FREQ** and **A** are pressed in the sequence listed.

NOTE

Neither frequency nor time of **DPL** or **DPL INVERT** can be recalled. Only frequency of **TN REM** and **TEL DL** can be recalled.

(15) **B** — used to enter into memory tone “B” frequency or time.

(16) **STEP** — stores increment frequency in memory.

(17) **A DELAY** — enters program time delay which occurs after “A” output.

(18) **TIME** — designates the displayed number as the duration of output tone.

(19) **A** — used to enter into memory tone “A” frequency or time.

(20) **FREQ** — designates the displayed number as the frequency of the output tone.

(21) 0 thru 9 — decimal number data entry switches.

(22) **TIMING Up Select Switch** — when pressed causes the timing sequence selected to advance upward.

(23) **TIMING Down Select Switch** — when pressed causes the timing sequence selected to advance downward.

(24) **TIMING** — By means of the **TIMING Up** or **Down Select Switch**, any one of the six timing sequences

is made available at the **BNC** output jack. The first four timing sequences are pre-programmed (see applications for time) and cannot be changed. **VARIABLE 1** and **VARIABLE 2** are programmed by the user for tone duration and delay. The seven segment display shows which timing sequence is selected.

(25) **CYCLE Switch** — is a three position switch. The **CONT** position causes a continuous output at the **BNC** jack. The **BURST** position is spring loaded and it returns to the off position after being pressed. This allows one complete cycle of output.

2.2.2 Rear Panel (See Figure 2-2)

The rear panel is part of the main chassis. It serves as a mounting frame for the ac power supply components. The items seen on the rear panel are as follows:

(1) Turn lock fasteners — two of these fasteners secure the housing to the main chassis.

(2) **12 V DC INPUT** — connector used for external dc voltage. When used, the internal batteries (optional) are automatically disconnected.

(3) **AC INPUT** — three prong input for 120 V ac or 220 V ac (optional wiring).

(4) **STROBE** — used to synchronize the coded output of additional code synthesizers.

(5) Power transformer cover.

(6) **AC Line Fuse** — rated at .25A for 120 V ac and .125A for 220 V ac (optional wiring).

(7) **DC Line Fuse** — rated at .75A for 12 V dc.

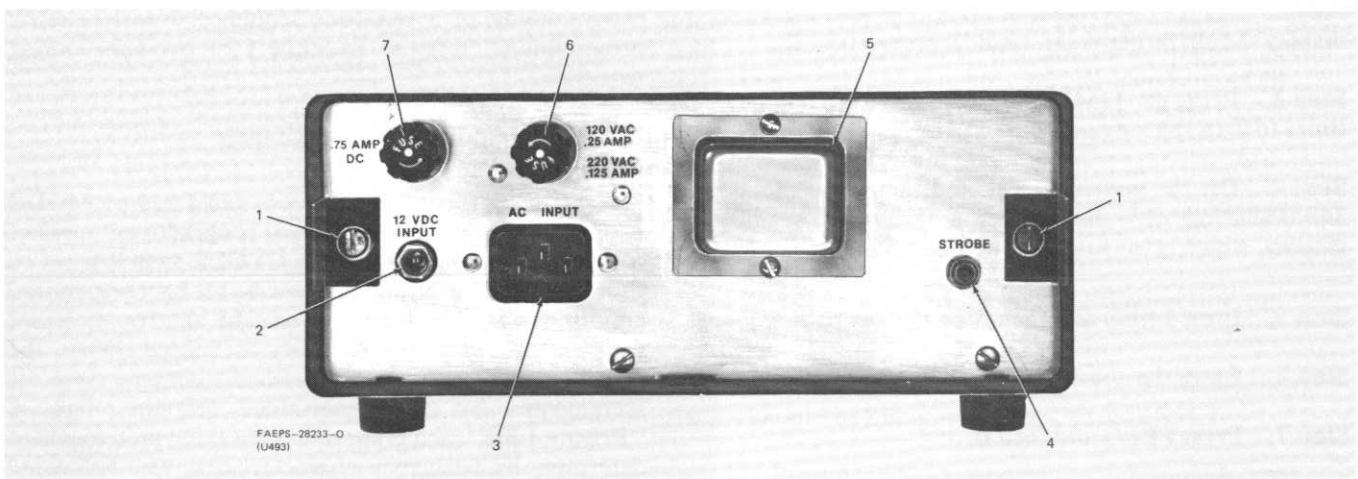

Figure 2-2. Rear Panel Location Detail

2.3 APPLICATIONS

The R-1100A Code Synthesizer uses keyboard entry for the programming of frequencies, time slots and code information. The following paragraphs explain how the programming is performed for the most commonly used applications.

2.3.1 Two-Tone Sequential Signaling

Four pre-programmed two-tone sequential timing sequences are stored in permanent memory locations in the code synthesizer. These are TONE ONLY, TONE-VOICE, TONE-BS (Battery Saver) and GROUP CALL (See Table 2-1). To operate in any one of these timing sequences, it is necessary to enter frequency only.

Table 2-1 Two-Tone Timing Sequences

Timing	A Duration	A Delay	B Duration	B Delay
TONE ONLY	.4 sec.	0.0 sec.	0.8 sec.	1.3 sec.
TONE VOICE	1.0 sec.	0.0 sec.	3.0 sec.	3.0 sec.
TONE BS	2.7 sec.	0.0 sec.	0.8 sec.	1.3 sec.
GROUP CALL	0.0 sec.	0.0 sec.	8.0 sec.	3.0 sec.
VARIABLE 1	user	user	user	user
	defined	defined	defined	defined
VARIABLE 2	user	user	user	user
	defined	defined	defined	defined

Two timing sequences are user defined: VARIABLE 1 and VARIABLE 2. To operate in either of these two timing sequences, it is necessary to program both time and frequency. Examples of programming two tone timing sequences are shown below.

Example 1. The TONE-VOICE timing sequence is to be programmed with frequencies of 349.0 Hz for tone A and 433.7 Hz for tone B.

Step 1. Apply power to the code synthesizer and turn-on POWER switch.

Step 2. Set CYCLE switch to OFF. The seven-segment display should be blank. If it is not, press RESET.

Step 3. Press the TIMING up or down switch enough times to light the indicator next to TONE-VOICE.

Step 4. On the numerical key pad, enter the number 349.0 starting with the number 3. The seven-segment display, which is left justified, now reads 349.0.

Step 5. Press FREQ and then A on the key pad.

Step 6. Enter the number 433.7.

Step 7. Press FREQ and then B.

Step 8. Press the MODE up or down switch enough times to light the indicator next to A.

Step 9. Set CYCLE switch to CONT and set LEVEL A to the required output. Return CYCLE switch to OFF.

Step 10. Press the MODE down switch once.

Step 11. Set CYCLE switch to CONT and set LEVEL B to the required output. Return CYCLE switch to OFF.

Step 12. Press the MODE down switch once so that the MODE A/B indicator is lit. This completes LEVEL set and frequency programming of a two-tone sequential signal.

Example 2. The VARIABLE 1 timing sequence is to be programmed with tone A duration 1.00 sec., A delay 0.5 sec.; tone B duration 0.5 sec., B delay .25 sec.

Step 1. Apply power to the code synthesizer and turn-on POWER switch.

Step 2. Set CYCLE switch to OFF. The seven-segment display should be blank. If not press RESET.

Step 3. Press the TIMING up or down switch enough times to light the indicator next to VARIABLE 1.

Step 4. On the numerical key pad, enter the number 1.00, starting with the number 1. The seven-segment display, which is left justified, now reads 1.00.

Step 5. Press TIME and then A on the key pad.

Step 6. Enter the number .5.

Step 7. Press TIME and then A DELAY.

Step 8. Enter the number .5, press TIME and then B on the key pad.

Step 9. Enter the number .25, press TIME and then B DELAY on the key pad. This step completes timing programming of a two-tone sequence. For frequency programming, refer to Example 1 of two-tone timing sequence.

2.3.2 "Private-Line" Tone Signaling

The "Private-Line" tone is generated on MODE A or B. The required frequency is programmed in either of these two modes. Then the CYCLE switch is set to CONT. The tone output can now be set for the required amplitude. Modes A and B can be set for different frequencies and used alternately as needed. When the STEP function is programmed, either tone is incremented by a predetermined amount. Thus a "Private-Line" reed is swept in very small increments to determine its frequency characteristics. The following two examples describe "Private-Line" tone and increment programming.

Example 1. MODE A is to be programmed with 179.9 Hz.

Step 1. Apply power to the code synthesizer and turn-on POWER switch.

Step 2. Set CYCLE switch to OFF. The seven-segment display should be blank. If not press RESET.

Step 3. Press the MODE up or down switch enough times to light the indicator next to A.

Step 4. On the numerical key pad, enter the number 179.9, starting with the number 1. The seven-segment display, which is left justified, now reads 179.9.

Step 5. Press **FREQ** and then **A** on the key pad.

Step 6. Set CYCLE switch to **CONT** and set LEVEL **A** to the required amplitude output.

Example 2. Frequency is to be swept across the "Private-Line" tone in 1.5 Hz increments.

Step 1. Repeat Steps 1 through 5 in Example 1, but program MODE A for 169.9 Hz. This is necessary because the step function increments in a positive direction only. This allows an incremental frequency sweep starting at 169.9 Hz and advancing through 179.9 Hz.

Step 2. Enter the number 1.5, and press **STEP** and **A** on the key pad.

Step 3. Set CYCLE switch to **CONT**.

Step 4. Press **STEP** and then **A** on the key pad.

Step 5. Press **A** on the key pad as many times as the frequency sweep requires.

2.3.3. "Digital Private-Line"

2.3.3.1 The R-1100A Code Synthesizer can generate a "Digital Private-Line" (DPL) code. It also can generate an inverted DPL code. The program code consists of a three digit octal number (see appendix for authorized codes). The code synthesizer is a DPL encoder only.

2.3.3.2 The DPL code is entered into memory and then is generated when the CYCLE switch is in either the **CONT** or **BURST** position. Since DPL is continuous modulation, the CYCLE switch is placed in **CONT** position. The code amplitude is controlled by LEVEL **A**. The signaling sequence for DPL is shown in Figure 2-3. Note that 133.0 is generated for 250 milliseconds at the end of the signaling sequence. This is the DPL turn-off code and appears at the end of all DPL signals. The following example shows how to program a DPL code.

Example: Program DPL CODE 131.

Step 1. Apply power to the code synthesizer and turn-on POWER switch.

Step 2. Set CYCLE switch to OFF. The seven-segment display should be blank. If it is not, press RESET.

Step 3. Press the MODE up or down select switch enough times to light the indicator next to DPL.

Step 4. On the numerical key pad, enter the number 131, starting with the number 1. The seven-segment display, which is left justified, now reads 131.

Step 5. Set CYCLE switch to **CONT** and set LEVEL **A** to required amplitude. This completes DPL programming and set-up.

NOTE

Because of DPL signal characteristics, timing and frequency is preprogrammed internally.

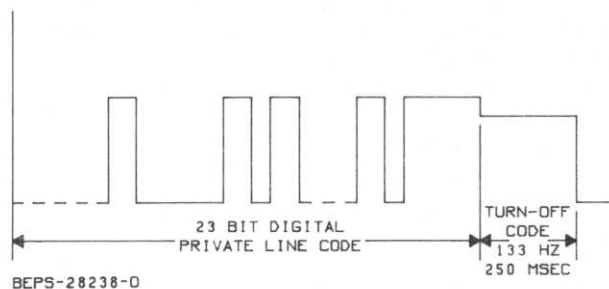

Figure 2-3. "Digital Private-Line" Signal Detail

2.3.4 Tone Remote

Tone Remote (TN REM) is a two-tone signaling sequence. Tone A is the guard tone, and tone B is the function tone (see Figure 2-4). The sequence is guard tone, function tone and low level guard tone (30 dB attenuation). The timing of the TN REM signaling is preprogrammed. Only the frequencies of these tones must be entered (see appendix for commonly used frequencies). The following example shows how to program and set-up tone remote signaling.

Example: Program 2175 Hz guard tone and 1950 Hz function tone.

Step 1. Apply power to the code synthesizer and turn-on POWER switch.

Step 2. Set CYCLE switch to OFF. The seven-segment display should be blank. If it is not, press RESET.

Step 3. Press MODE up or down switch enough times to light the indicator next to A.

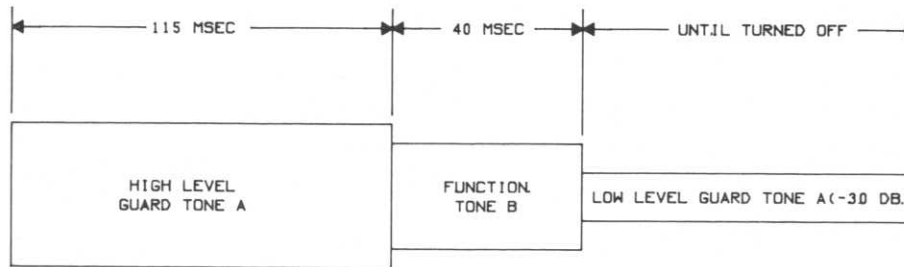

BEPS-28239-0

Figure 2-4. Tone Remote Signal Detail

Step 4. On the numerical key pad, enter the number 2175, starting with number 2. The seven-segment display, which is left justified, now reads 2175.

Step 5. Press **FREQ** and then **A** on the key pad.

Step 6. Set **CYCLE** switch to **CONT** and set **LEVEL A** to required output. If a balanced 600 ohm line is being fed, a line matching transformer is required. Use **RTL-1003A Transformer Kit** (see accessories).

Step 7. Return **CYCLE** switch to **OFF**.

Step 8. Press **MODE** down switch once. The indicator next to **B** is now lit.

Step 9. Enter 1950, press **FREQ** and then **B**, set **CYCLE** switch to **CONT** and set **LEVEL B**. Return **CYCLE** switch to **OFF**.

Step 10. Press **MODE** up or down switch enough times to light the indicator next to **TN REM**.

Step 11. Set **CYCLE** switch to **CONT**. Tone remote signaling sequence is outputted. This completes the programming and level setting for tone remote.

2.3.5 IMTS and 2805 Interrupt Dialing

The **IMTS** and **2805 Interrupt Dialing** are two-tone signaling sequences. The timing is pre-programmed (see Figure 2-5), and only the frequencies (see appendix) and dialing number need be entered. In **Improved Mobile Telephone Systems (IMTS)**, 2000 Hz is used for Idle tone and 1800 Hz for Seize tone. **Interrupt dialing** uses zero and 2805 Hz. The following examples show how to program and set-up **IMTS** and **2805 Interrupt Dialing** signals.

Example 1. **IMTS** dialing signal with 2000 Hz Idle tone, 1800 Hz Seize tone and 8888888 dialing.

Step 1. Apply power to the code synthesizer and turn-on **POWER** switch.

Step 2. Set **CYCLE** switch to **OFF**. The seven-segment display should be blank. If it is not, press **RESET**.

Step 3. Press **MODE** up or down select switch enough times to light the indicator next to **A**.

Step 4. On the numerical key pad, enter the number 2000, starting with number 2. The seven-segment display, which is left justified, now reads 2000.

Step 5. Press **FREQ** and the **A** on the key pad.

Step 6. Set **CYCLE** switch to **CONT** and set **LEVEL A** to required output. If a balanced 600 ohm line is being fed, a line matching transformer is required. Use **RTL-1003A Transformer Kit** (see accessories).

Step 7. Return **CYCLE** switch to **OFF**.

Step 8. Press the **MODE** down switch once. The indicator next to **B** is lit.

Step 9. Enter 1800, press **FREQ** and the **B**, set **CYCLE** switch to **CONT** and set **LEVEL B**. Return **CYCLE** switch to **OFF**.

Step 10. Press **MODE** up or down switch enough times to light the indicator next to **TEL DL**.

Step 11. Enter 8888888 dialing on the key pad.

Step 12. Set **CYCLE** switch to **BURST** or **CONT**. The display goes blank and the signaling sequence starts. This completes programming of **IMTS** dialing.

Example 2: **2805 Interrupt Dialing** with zero tone A, 2805 tone B and 8888888 dialing.

Step 1. Repeat Steps 1 thru 12 in Example 1. But use zero and 2805 Hz in Steps 4 and 9, respectively for two-tone signaling sequence.

Step 2. This completes programming of **2805 Interrupt Dialing**.

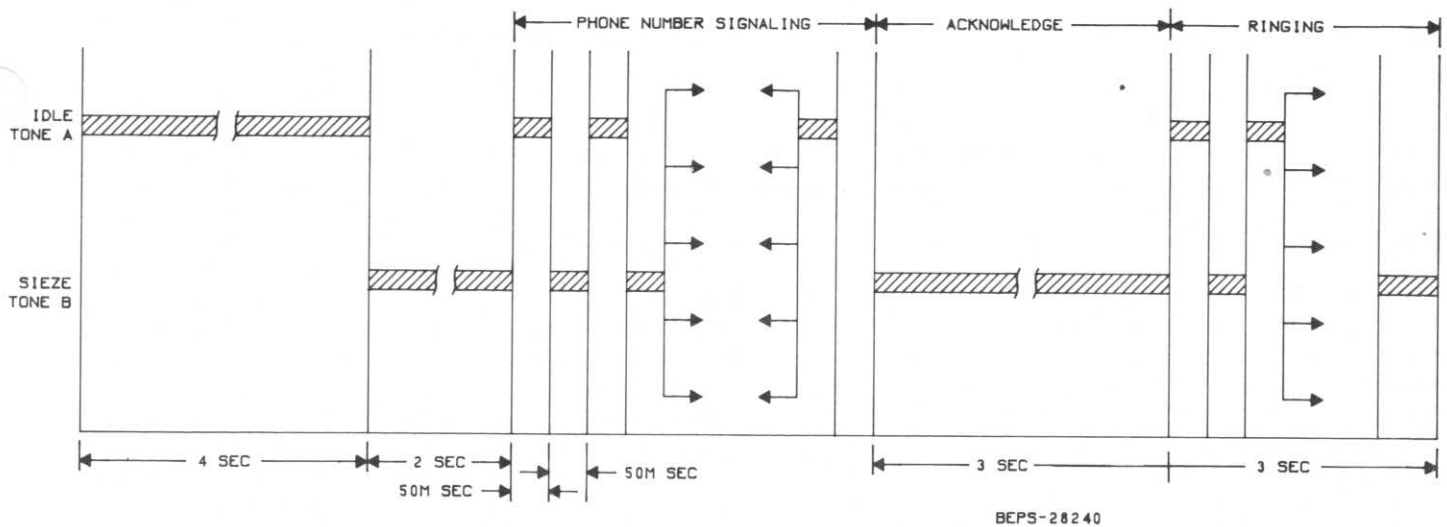

Figure 2-5. IMTS and 2805 Interrupt Dialing Signal Detail

3. THEORY OF OPERATION

3.1 INTRODUCTION

(See Section 5 — Diagrams and Parts List)

3.1.1 The R-1100A Code Synthesizer is an audio frequency synthesizer that has a frequency range from 10 Hz to 9999 Hz. It has a single or a two-tone signaling output.

3.1.2 All timing sequences for two-tone sequential signaling are handled within the microprocessor software. The fixed timing requirements of TONE ONLY, TONE and VOICE, TONE BS and GROUP CALL reside in the microprocessor memory designated as a look-up table. When the CYCLE switch is closed the microprocessor determines what timing sequence is required and what MODE is required. In the A/B MODE, the processor will look at the memory location that tone A was entered in, set up the rate multipliers, select the proper dividers and switches, select the proper filter and then keep tone A on for the required length of time. It will then shut off tone A, go through a timing routine for A delay (the duration between tone A and tone B), and then go through the same process for tone B and delay. This process is the same no matter what timing sequence is required for two-tone signaling. Two variable timing slots are available to the user so unique timing sequences can be entered.

3.1.3 The CYCLE switch has two operations. The BURST cycle tells the microprocessor to go through only one cycle of tone A, A delay, tone B, and B delay. The CONT cycle (continuous) repeats the cycle until the CYCLE switch is returned to the OFF position.

3.1.4 The same procedure is used in TEL DL (Telephone Dialing) and TONE REMOTE. The timing for these modes resides in the look-up table also.

3.1.5 DPL and DPL invert, Motorola's "Digital Private-Line", are generated strictly in software, i.e., the code requires no hardware manipulation. Three octal numbers are entered via the keyboard, and a software algorithm determines the required 23 bit code. This code is routed to the audio amplifiers and filters so proper wave shaping is done to meet two-way land mobile frequency response requirements.

3.1.6 The signal generating operations of this instrument are divided into seven principle sections. These sections are as follows:

- USER INTERFACE — composed of the data entry keyboard and LED readouts.
- FREQUENCY GENERATION — comprised of the crystal controlled oscillator, BCD rate multipliers and dual 4-bit latch (U102), frequency divider and four-to-one switch.
- DIGITAL-TO-ANALOG CONVERTER
- HARMONIC FILTERS
- AUDIO AMPLIFICATION — consisting of signal attenuators and audio amplifiers.
- AUDIO OUTPUT FOR ENTRY VERIFICATION
- POWER SUPPLY

3.1.7 Four of these sections are either controlled or monitored by the microprocessor. The four sections which interface with the microprocessor are User Interface, Frequency Generation, Harmonic Filters, and Audio Output for Entry Verification.

3.2 USER INTERFACE

3.2.1 The User Interface allows an operator to enter data into program sequence of the microprocessor. It also tells the operator by means of a readout display what is being generated by the Code Synthesizer. The User Interface consists of the controls, switches and displays on the front and rear panels.

3.2.2 When the unit is turned on, U106B and C initialize the microprocessor to its start-up routine. This routine includes setting the BCD rate multipliers to zero frequency, multiplexing the LED readouts, indicators, and keyboard lines, searching for a key closure, blanking the LED seven-segment displays and lighting the TONE ONLY Timing and A/B MODE states. The microprocessor is now waiting for the user to make an entry via the keyboard. When a key closure is sensed, the microprocessor determines which key has been closed and outputs to the LED seven-segment display any change that is required. For example, if the number "1" was closed, the microprocessor displays the number "1" on the seven-segment display. Or if Timing was changed from TONE ONLY to GROUP CALL, the microprocessor lights up the GROUP CALL indicator. When a valid closure is made, a beep, which is generated by the microprocessor, is heard. After the proper sequence is followed for entering frequency, MODE and TIMING states (see operation), the microprocessor waits for a cycle command which is entered via the CYCLE switch. After this has been done, the LED displays are multiplexed with the new information.

3.3 FREQUENCY GENERATION

The CYCLE switch starts the microprocessor into its generating mode. If the MODE of operation is not DPL or DPL INVERT, then all tones are generated by the microprocessor through the rate multipliers, dividers, Walsh generator (D/A converter), filters and audio amplifier. For single tone operation, when the CYCLE switch is operated, the microprocessor takes the frequency entered for tone A (or B) and latches the lower two digits to Rate Multipliers 3 & 4 and then inputs the upper two digits to U110 and U111 Rate Multipliers. For example, if the frequency entered is 1234, then the microprocessor would output to U102 eight-bit latch the BCD (binary coded decimal) equivalent of 3 & 4 and then latch it to U112 and U113 Rate Multipliers. It would then output to U110 and U111 Rate Multipliers the BCD equivalent of 1 and 2.

3.4 DIGITAL-TO-ANALOG CONVERTER

The actual frequency output from the analog switches is 32 times the frequency entered. This is because the Walsh generator D/A converter requires 32 bits of digital information to produce a single cycle of a sine wave.

3.5 HARMONIC FILTERS

Because a D/A converter is not totally accurate in reproducing an analog signal, harmonic distortion appears with the sine wave. Harmonic distortion can be reduced by reducing the amplitude of the unwanted harmonics. Microprocessor controlled three pole filters (U126A and B, U115B) are used to reduce this total harmonic distortion. For ease and efficiency, one of four filters is selected by the microprocessor to reduce unwanted harmonics, and the filter selected depends on the frequency selected. If the selected frequency is between 10 and 99 Hz, the filter selected has a -3 dB point of 167 Hz; between 100 and 999 Hz, the selected filter has a -3 dB point of 1.77 kHz; between 1 kHz and 4999 Hz, the selected filter has a -3 dB point of 12 kHz and between 5 kHz and 9999 Hz, the selected filter has a -3 dB point of 21.5 kHz. The reason for these apparent random -3 dB points is that the Walsh D/A converter theoretically will not contain harmonics until the 31st, thus making the three pole low pass filter an effective method of reducing harmonic distortion.

3.6 AUDIO AMPLIFICATION

After a usable analog signal is obtained from U115B-13, it goes to U124 and U123, signal attenuators. Components U123A and B are microprocessor controlled for 30 dB signal reduction used in tone remote signaling (see Operating Instructions). Front panel controls R152 and R153 are used to set tone LEVELS A and B. The signal then goes through audio amplifier Q104 thru Q109. These transistors reduce distortion and amplify the signal to 3 V rms into a 600-ohm load.

3.7 AUDIO OUTPUT FOR ENTRY VERIFICATION

Each time a valid user entry is made there will be an audio tone (beep) generated to verify this entry. For each valid user entry, the microprocessor generates a positive pulse at U122-4. The output of U122-6 causes U121 to generate an audio tone which is amplified by Q109. Transducer LS101 converts the electrical signal to sound.

3.8 POWER SUPPLY

3.8.1 The code synthesizer operates from 110 V ac, 220 V ac (optional wiring) or 12 V dc. The power transformer is wired for 110 or 220 V ac. The power supply schematic diagram shows the optional 220 V ac wiring.

3.8.2 The output from the transformer is full-wave rectified and applied to U109, a positive 15 volt regulator. Regulator U108 and operational amplifier U127 provide additional regulation and voltage division.

3.8.3 The 12 V dc operation is from an externally connected line cord or an internally connected battery pack (optional). The battery pack is recharged through U401. When external dc power is used, the internal battery pack, if used, is automatically disconnected.

4. MAINTENANCE

4.1 ROUTINE MAINTENANCE

A regular program for maintenance and inspection every five to six months is recommended for this unit. As part of this program, the unit should be checked as follows.

Check 1. Disconnect ac power and remove the housing. (See Housing Removal paragraph.)

Check 2. Make a thorough visual inspection of all wiring and cables. Check for frayed, loose, or burned wires.

Check 3. Inspect components for their physical integrity. Look for burned or cracked components, loose solder connections, leakage of insulation compounds, and general physical damage. Ensure that all plug-in components, such as integrated circuits, transistors and connectors, are firmly seated in their mating sockets. Never unnecessarily remove and replace a plug-in component.

Check 4. Operate user switches and controls and check for loose or sticking shafts, etc.

Check 5. Inspect circuit boards and components for an excessive amount of dust deposited on them. Use a soft brush and low-pressure air stream to remove the dust.

CAUTION

Do not clean the circuit boards or small components with a stiff brush or solvents, since damage may result. A high-powered vacuum cleaner or air stream should not be used on small components.

Check 6. Clean the external surfaces of the unit with a soft, damp cloth to remove dirt, fingerprints, and other foreign materials.

Check 7. Replace the housing and reconnect power. Check performance. If performance does not equal or exceed the SPECIFICATIONS, corrective maintenance may be required.

CAUTION

The code synthesizer includes CMOS devices which require special handling techniques to prevent irreparable damage

from static charges. Refer to the SAFE HANDLING OF CMOS INTEGRATED CIRCUIT DEVICES instruction section 68P81106E84.

4.2 HOUSING REMOVAL

Step 1. Disconnect all power lines, either ac and/or dc. If battery pack option is used, be sure the POWER switch is in the OFF position.

Step 2. Turn lock fasteners on the rear panel until the screws release.

Step 3. Slide housing off the main chassis.

Step 4. If battery pack option is used, unscrew the four screws on the chassis side rails and remove battery pack. Unsolder the wire to the main board.

4.3 CALIBRATION

The R-1100A Code Synthesizer must be calibrated with a frequency counter that has a specified accuracy of .001% or better.

4.3.1 Required Test Equipment

Frequency Counter — Motorola S-1343AB recommended.

Digital Voltmeter — Motorola Model R-1001A recommended.

4.3.2 Calibration Procedure

Step 1. Disconnect all power lines, either ac and/or dc. Remove housing as described in Housing Removal paragraph.

Step 2. Connect ac power and set POWER switch to ac.

Step 3. Make the following dc voltage measurements:

Pin 3	U109 — + 15 V dc \pm .6 V dc.
Pin 3	U108 — + 5 V dc \pm .2 V dc.
Pin 7	U127 — + 15 V dc \pm .5 V dc.
Pin 6	U127 — + 7.5 V dc \pm .25 V dc

Step 4. Enter 10 Hz into tone A as described in the OPERATING INSTRUCTIONS, "Private-Line" Tone Signaling.

Step 5. Connect the BNC output of the code synthesizer to the frequency counter input.

Step 6. Set the CYCLE switch to CONT.

Step 7. Adjust the A LEVEL control until the counter reading is stable (should be approximately 10.00 Hz).

Step 8. Adjust C110 until the counter indication is $10.00 \pm .001$ Hz.

Step 9. Set POWER switch OFF, disconnect the BNC cable and replace housing.

4.4 CORRECTIVE MAINTENANCE

Because of the single chip microprocessor and the high degree of multiplexing involved, detailed troubleshooting procedures are not possible. In most cases, the display board, RTL-4051A, will have to be sent to Motorola National Parts for repair. The following procedures will determine which board needs repair, either the RTL-4051A Display Board or the RTL-4050A Main Logic Board, or if the microprocessor needs to be replaced.

Step 1. Disconnect all power lines, either ac and/or dc. Remove housing as described in Housing Removal paragraph.

Step 2. Connect ac power and set POWER switch to ac.

Step 3. Set CYCLE switch to OFF position.

Step 4. When the unit is turned on, the TIMING TONE ONLY indicator should be lit and the MODE A/B indicator should be lit. If this is not true, proceed to Step 6. If they are lit, continue to Step 5.

Step 5. With a dc voltmeter, measure the voltages listed in Table 4-1. If a measurement does not agree, proceed as directed by the comments. If all dc measurements are correct, proceed to Step 7.

Step 6. If the proper indicators are not lit, then the display board or microprocessor is defective. Both must be sent to Motorola National Parts for repair. Proceed to Step 8.

Step 7. Enter 1000 Hz into the code synthesizer as described by the OPERATING INSTRUCTIONS for PL signaling. Waveforms WF-1 thru WF-8 should appear at the points marked on the schematic diagram with the output adjusted for 3 V rms into a 600-ohm load.

NOTE

If a waveform is not present, continue to Step 8. If the waveforms are correct, repeat Step 7 with 10 Hz, then 100 Hz, then 5000 Hz. The waveforms for these frequencies should be similar, except for period. If they are correct, check wiring from the BNC output to RTL-4050A Main Logic Board.

Step 8. Set POWER switch to the OFF position. Remove microprocessor U101.

Step 9. Set POWER switch to ac.

Step 10. Ground pins 8, 9, 10, 11, 12, 13, 14, 15 of U101 socket. Touch pin 33 of U101 socket to Vcc 4 (+5 V dc) then return to ground.

Step 11. Tie Pin 14 of U101 socket to +5 V dc.

Step 12. Observe waveforms WF-1 thru WF-8. If they are correct, the microprocessor is defective and must be returned to Motorola National Parts. If they are not correct, replace the proper IC's to correct the fault.

Step 13. Replace cover as previously described.

Table 4-1. Troubleshooting Voltage Measurements

TEST POINTS	MEASUREMENT	COMMENT
Pin 3 U109	+ 15 V dc \pm .6 V dc	Replace U109, trace dc path
Pin 3 U108	+ 5 V dc \pm .2 V dc	Replace U108, trace dc path
Pin 7 U127	+ 15 V dc \pm .5 V dc	Check dc path from J100 to U127
Pin 6 U127	+ 7.5 V dc \pm .25 V dc	replace U1, trace dc path
Pin 7 U124	+ 5.3 V dc	Replace U124
Pin 14 U124	+ 7.0 V dc	Replace U124
Pin 8 U124	+ 7.5 V dc	Replace U124
Pin 15 U123	+ 7.5 V dc	Replace Q108
Emitter Q103	0.7 V dc	Replace Q103
Emitter Q104	0.60 V dc	Replace Q104
Base Q106	8.2 V dc	Replace Q106
Pin 1 P100	+ 5 V dc \pm .2 V dc	Unplug J100 and remeasure. If still bad, replace U108. If good, the display board must be repaired or replaced.

4.5 RETURNING EQUIPMENT TO FACTORY

4.5.1 General Information

Contact your nearest Motorola Parts and Service Depot prior to returning the Code Synthesizer. Package the unit in the original container or follow the Packing Instructions given below. In either case, attach a tag to the unit indicating its model number and serial number, the name and address of the owner, and a summary of the service or repairs required.

4.5.2 Packing Instructions

Step 1. Wrap the unit in heavy paper or plastic prior to placing it into the shipping container.

Step 2. Use a strong carton or wooden box as the shipping container.

Step 3. Use an adequate layer of shock-absorbing material on all sides of the unit and protect the front

panel with additional layers of cardboard. Be certain that there is no movement of the unit within the shipping container.

Step 4. Seal the shipping container with strong tape or metal bands.

Step 5. Mark the shipping container "FRAGILE-DELICATE INSTRUMENT" to alert shippers that careful handling is required.

Step 6. Be certain that all correspondence refers to the unit's full model and serial numbers.

4.5.3 Parts and Service Address

National Accounts
1313 E. Algonquin Road
Schaumburg, Illinois 60196
Phone (312) 576-6509

SYSTEM BLOCK DIAGRAM

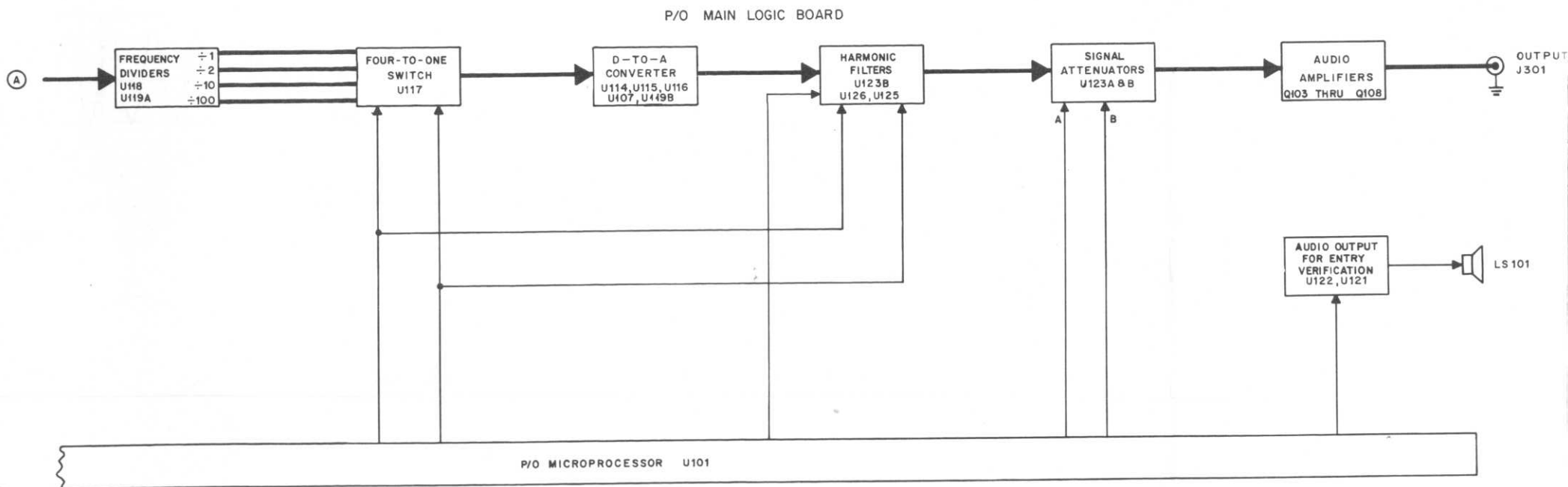
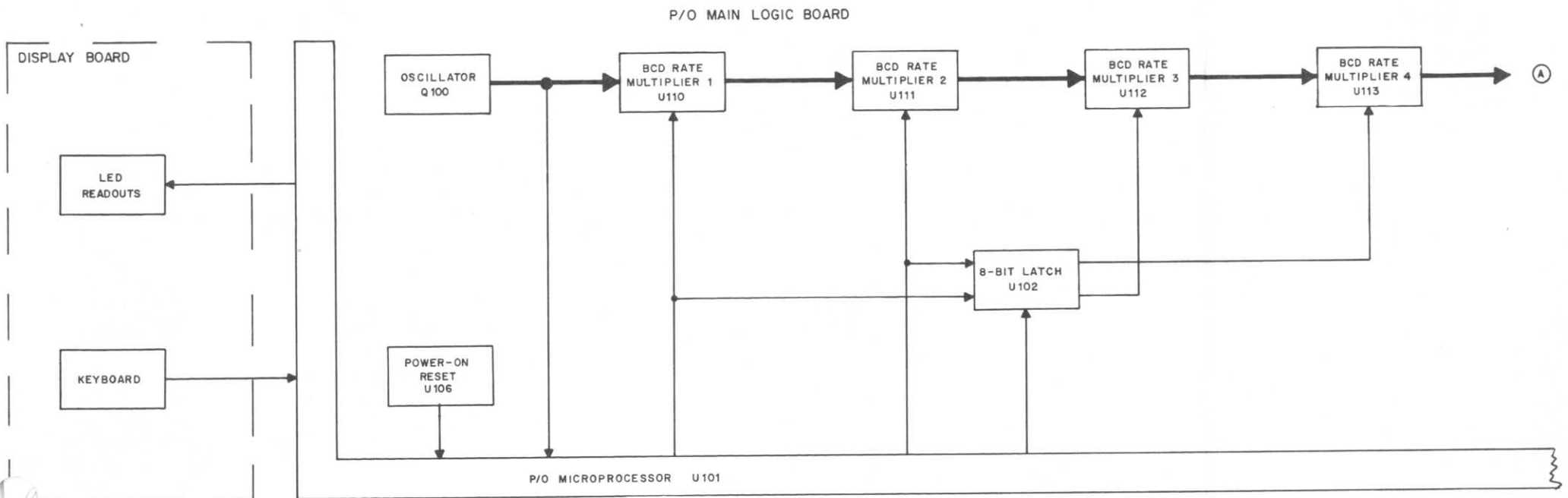

POWER SUPPLY SCHEMATIC

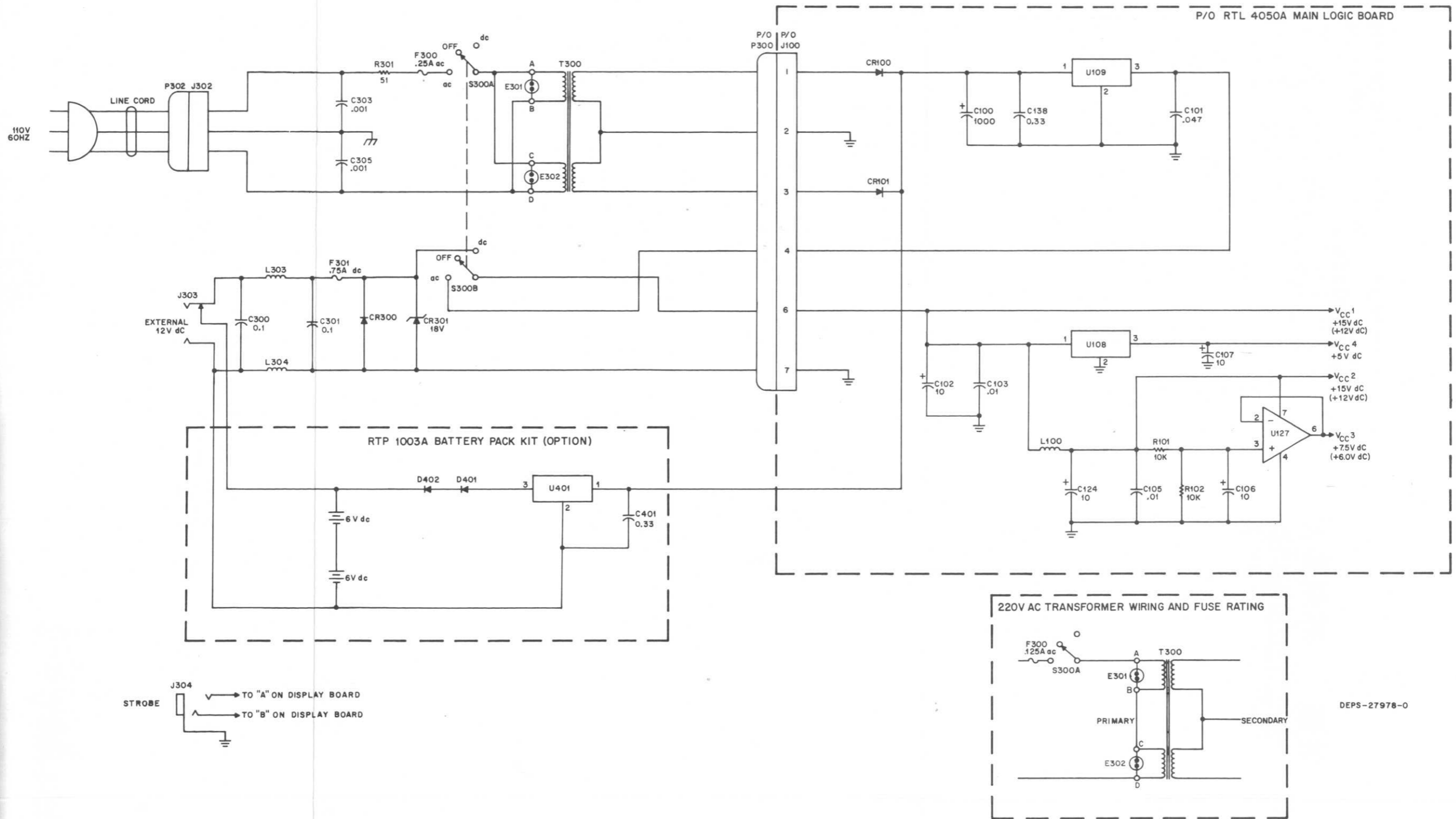

R-1100A Code Synthesizer
System Block Diagram and
Power Supply Schematic
Motorola No. PEPS-28255-O
2/16/79-

RTL-4051A DISPLAY BOARD

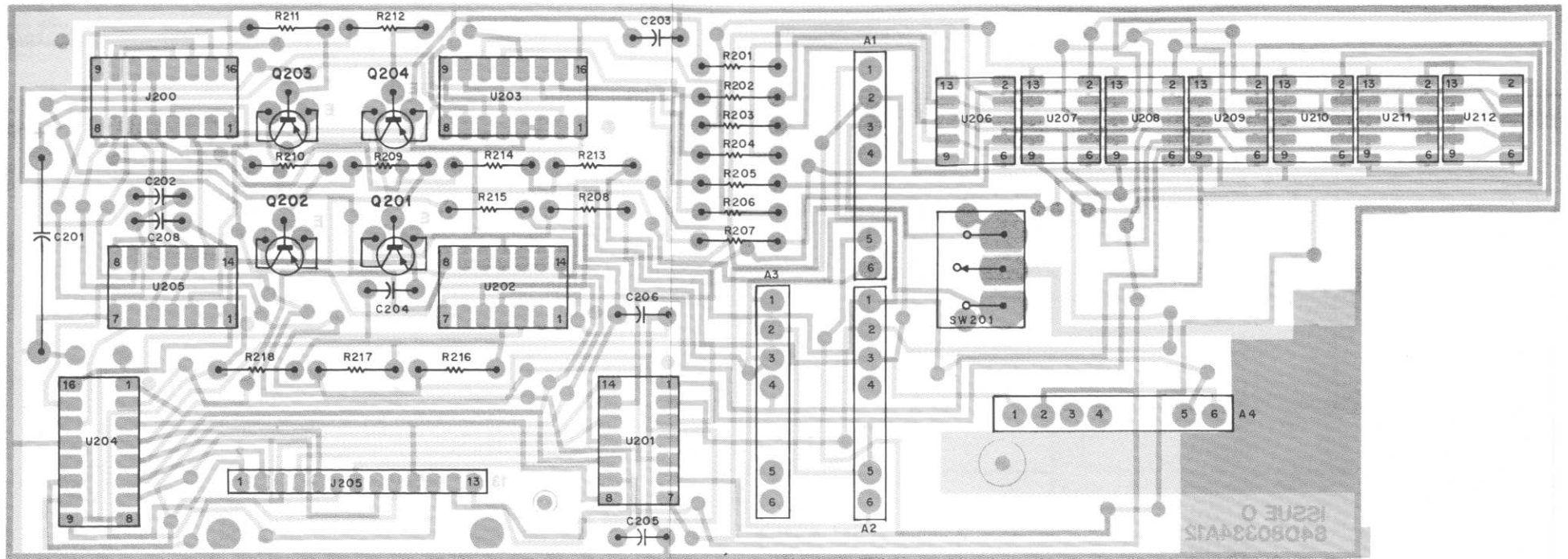

SHOWN FROM SOLDER SIDE

SOLDER SIDE ■ BD-DEPS-27965-0
 COMPONENT SIDE ■ BD-DEPS-27966-0
 OL-DEPS-27967-0

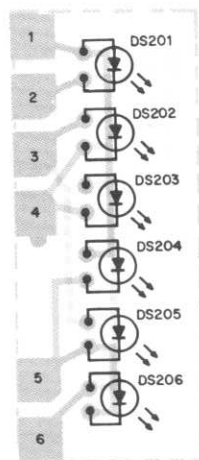

SOLDER SIDE ■ BD-BEPS-27968-0
 COMPONENT SIDE ■ BD-BEPS-27969-0
 OL-BEPS-27970-0

A1

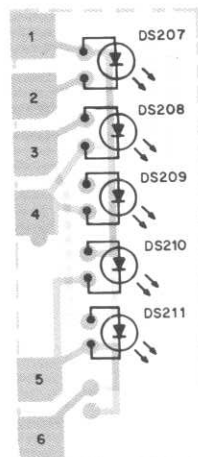

SOLDER SIDE ■ BD-BEPS-27968-0
 COMPONENT SIDE ■ BD-BEPS-27969-0
 OL-BEPS-27971-0

A2

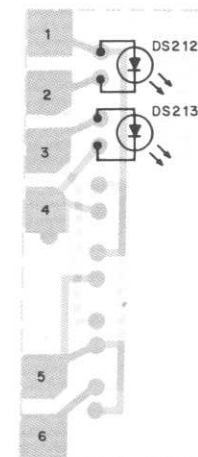

SOLDER SIDE ■ BD-BEPS-27972-0
 COMPONENT SIDE ■ BD-BEPS-27973-0
 OL-BEPS-27974-0

A3

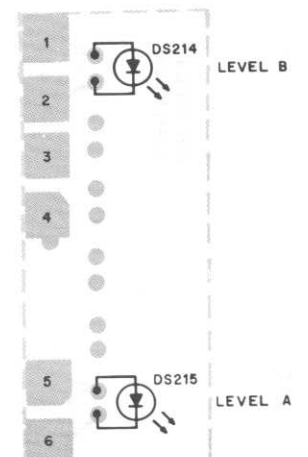

SOLDER SIDE ■ BD-BEPS-27975-0
 COMPONENT SIDE ■ BD-BEPS-27976-0
 OL-BEPS-27977-0

A4

LED BOARD

(SHOWN FROM COMPONENT SIDE)

RTL-4050A MAIN LOGIC BOARD

SCHEMATIC WAVEFORMS

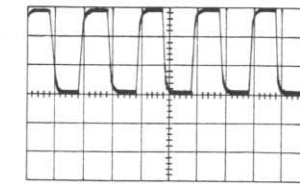
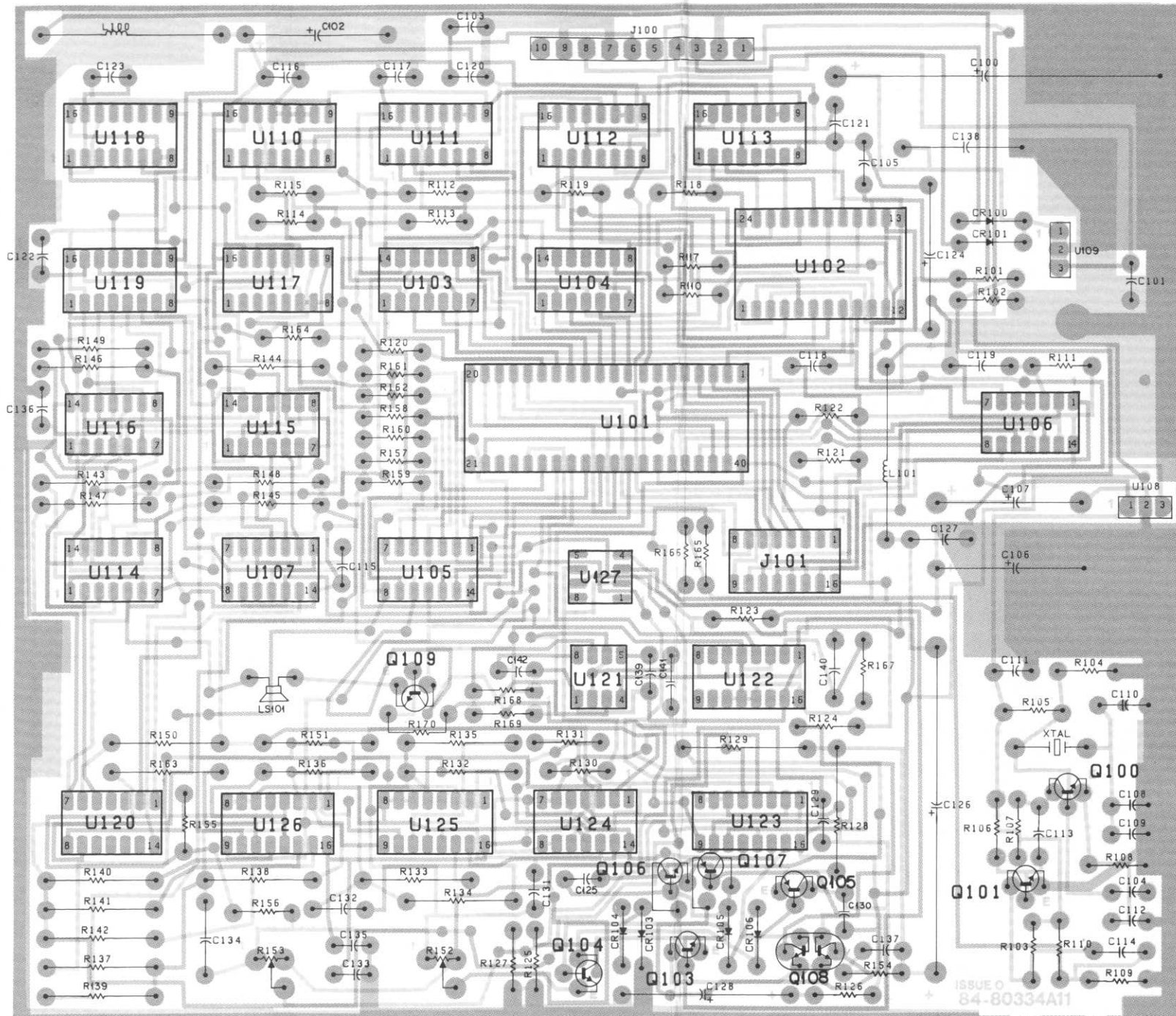

WF-1 OUTPUT U120B-2
5 V/DIV
.2 MICROSECONDS/DIV

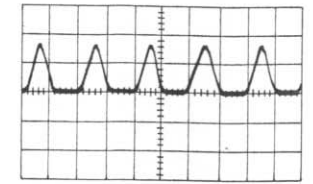

WF-2 INPUT U101-2
2 V/DIV
.2 MICROSECONDS/DIV

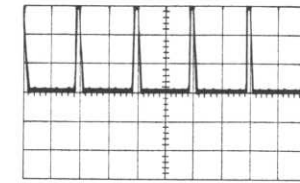

WF-3 OUTPUT U113-6
5 V/DIV
1 MICROSECOND/DIV

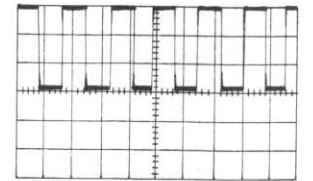

WF-4 OUTPUT U117-13
5 V/DIV
20 MICROSECONDS/DIV

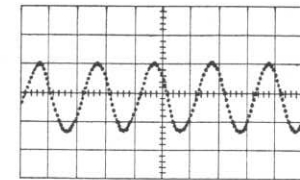

WF-5 OUTPUT U124A-1
2 V/DIV
.5 MILLISECOND/DIV
+2 V REFERENCE AT BOTTOM

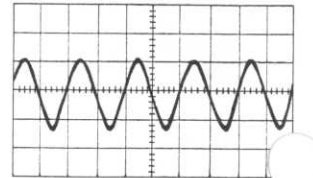

WF-6 OUTPUT U124D-14
2 V/DIV
.5 MILLISECOND/DIV
+2 V REFERENCE AT BOTTOM

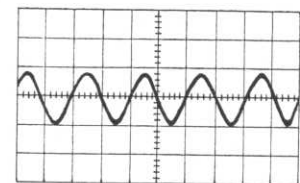

WF-7 OUTPUT U123A-15
2 V/DIV
.5 MILLISECOND/DIV
+2 V REFERENCE AT BOTTOM

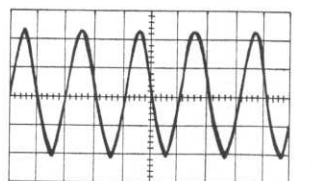

WF-8 AT TIE-POINT C126,
C127 AND L101
2 V/DIV
.5 MILLISECOND/DIV

GBEPS-28243-0

ISSUE 0
84-80334A11
COMPONENT SIDE • BD-DEPS-27962-0
SOLDER SIDE • BD-DEPS-27963-0
OL-DEPS-27964-0

SHOWN FROM COMPONENT SIDE

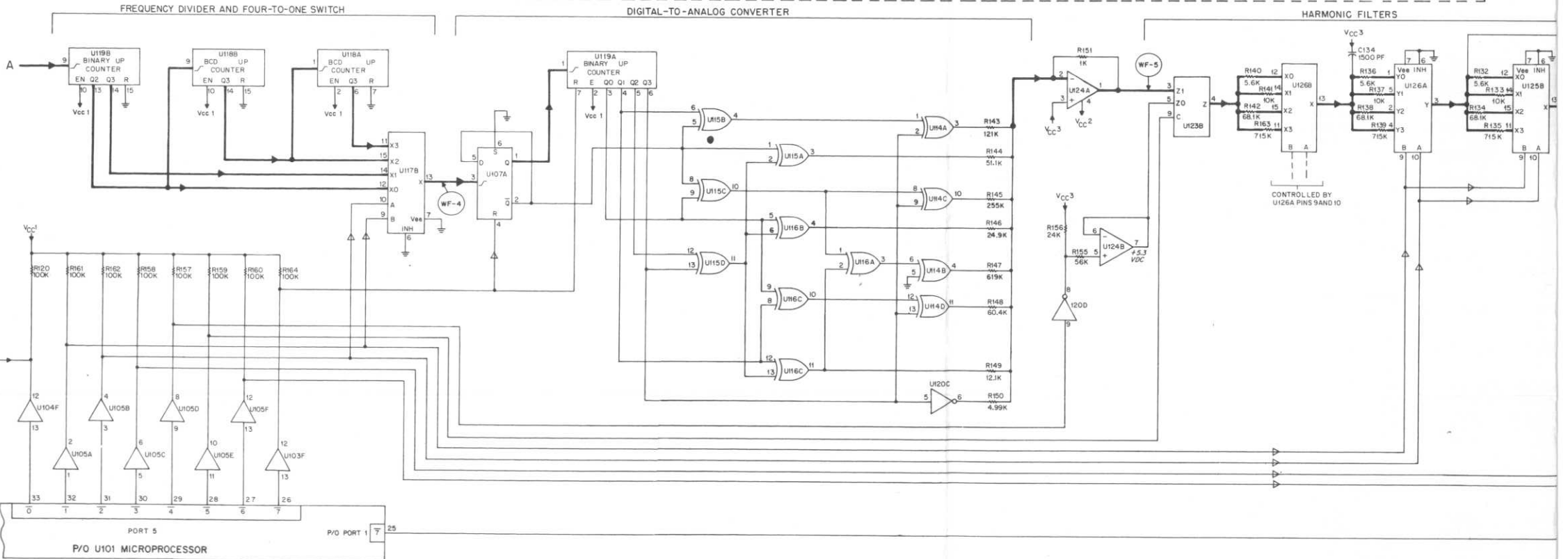
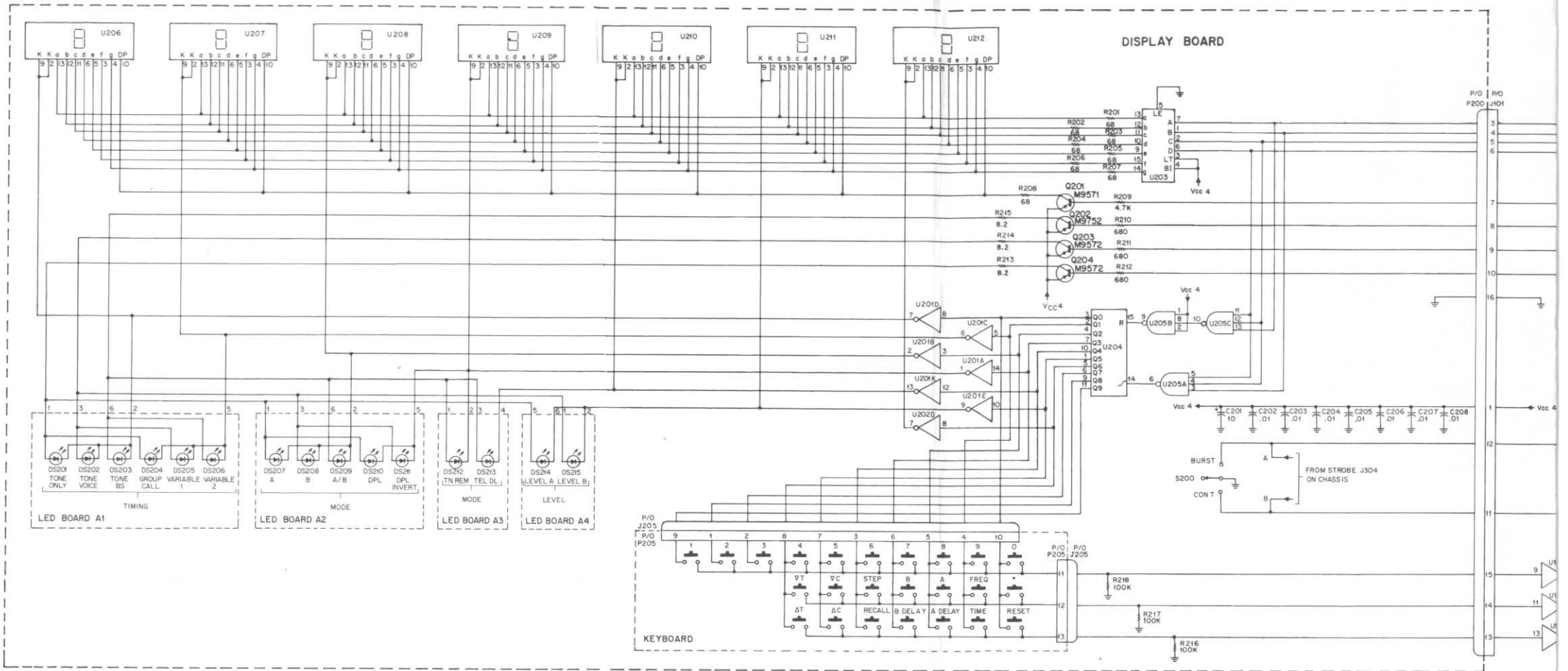

MAIN LOGIC BOARD

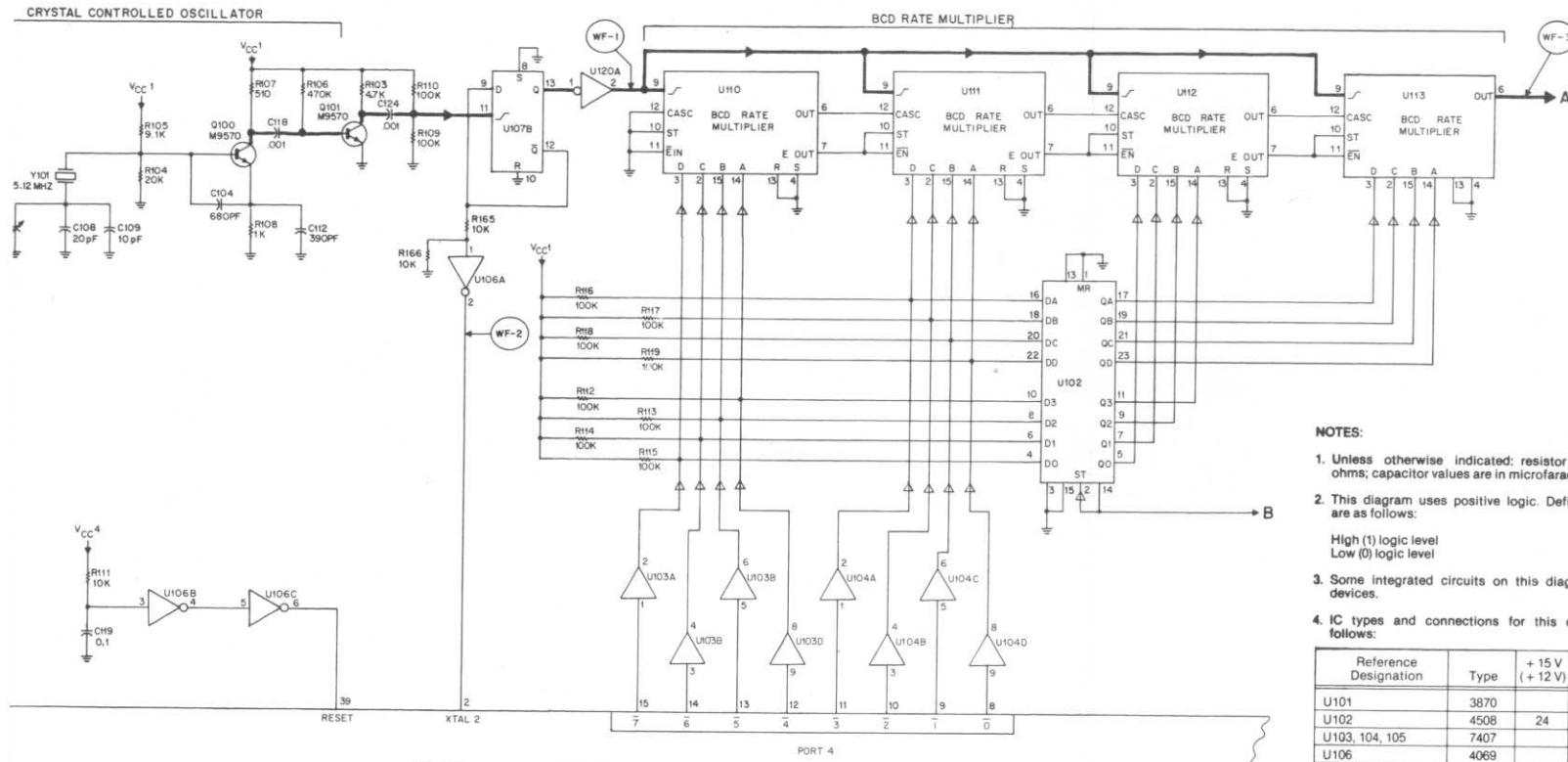

NOTES:

- Unless otherwise indicated: resistor values are in ohms; capacitor values are in microfarads.
- This diagram uses positive logic. Defined logic levels are as follows:
High (1) logic level volts
Low (0) logic level volts
- Some integrated circuits on this diagram are CMOS devices.
- IC types and connections for this diagram are as follows:

Reference Designation	Type	+15 V (+12 V)	+7.5 V (+6.0 V)	+5 V	GND	Manufacturer's Description
U101	3870			40	20	Microprocessor
U102	4508	24				Dual 4-Bit Latch
U103, 104, 105	7407			14	7	Hex Buffer
U106	4069			14	7	Hex Inverter
U107	4013	14			7	Dual D Flip-Flop
U108	7805			2		5 Volt Regulator
U109	7815			2		15 V Regulator
U110, 111, 112, 113	4527	16			8	BCD Rate Multiplier
U114, 115, 116	4070	14			7	Quad Exclusive "OR"
U117	4052	16			8	Dual 4-Channel Analog Multiplexer
U118	4518	16			8	Dual BCD Up Counter
U119	4520	16			8	Dual Binary Up Counter
U120	4069	14			7	Hex Inverter
U121	455			8	1	Timer
U122	4528			16	8	Dual Monostable
U123	4053	16			8	Triple 2-Channel Analog Multiplexer
U124	3403	4			11	Quad Operational Amplifier
U125, 126	4052	16			8	Dual 4-Channel Analog Multiplexer
U127	741	7			4	Operational Amplifier
U201, 202	SN75492			11	4	Hex Inverter
U203	4511			16	8	BCD-to-Seven Segment Latch/Decoder/Driver
U204	4017			16	8	Decade Counter/Divider
U205	4023			14	7	3-Input "NAND" Gate
U206 thru U212	TIL313					Seven Segment LED
U401	7815			2		15 Volt Regulator

- The following are .01 microfarad filter capacitors connected to the Vcc voltage. For each capacitor location, see circuit board diagram:
Capacitors: C111, 112, 115 thru 118, 120 thru 123, 129, 130, 133, 135, and C201 thru C207.

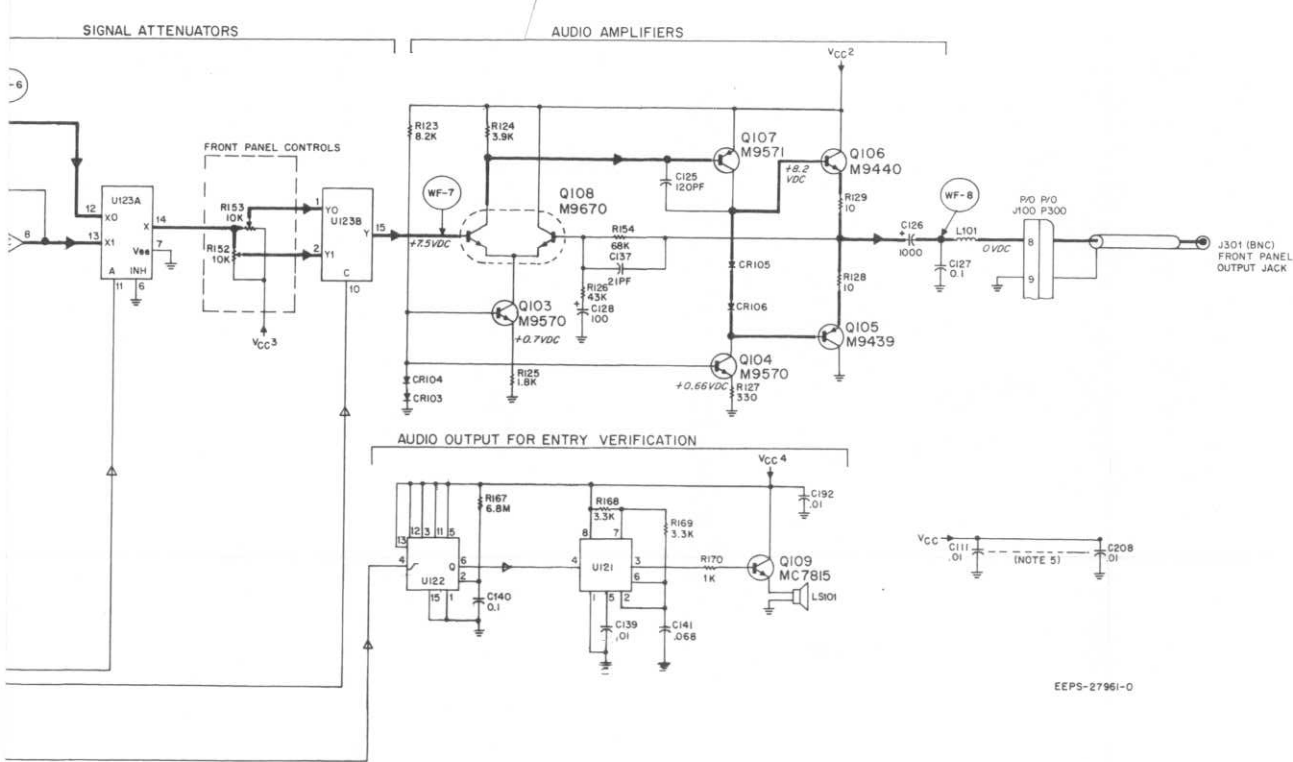

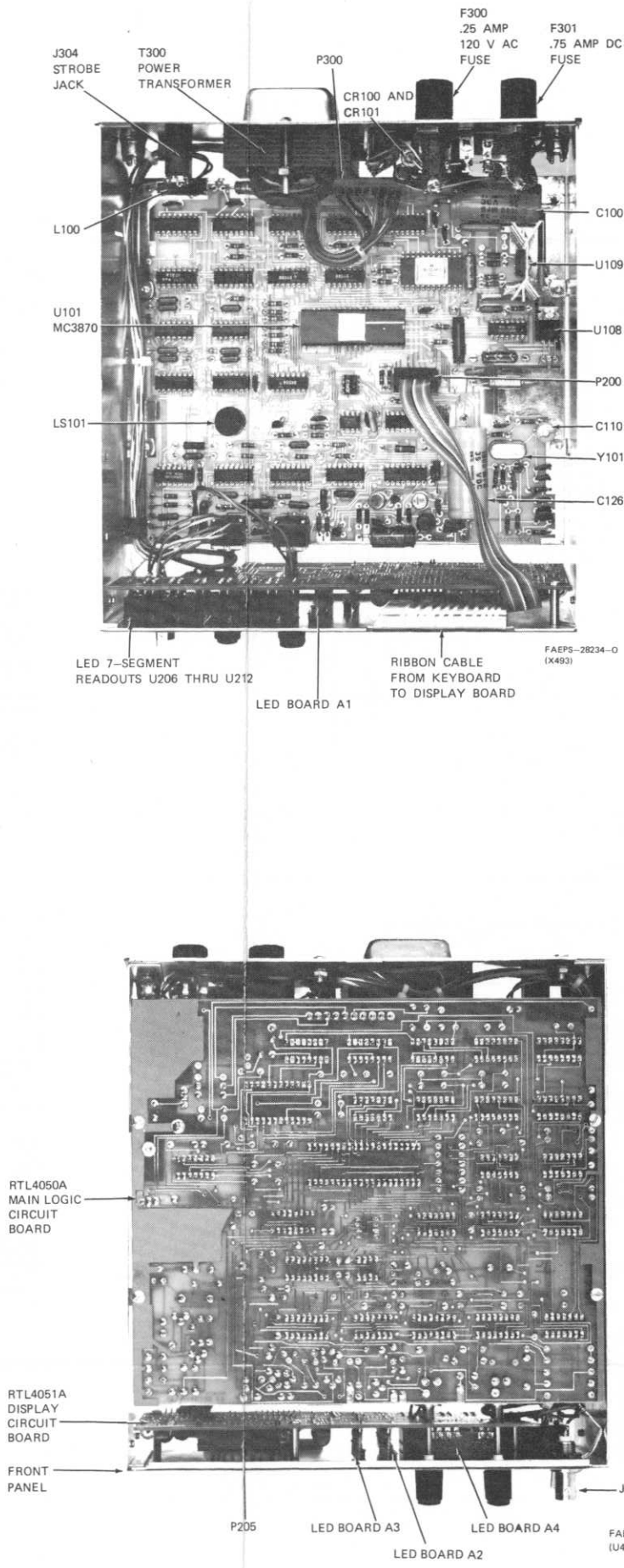

Figure 5-2. Chassis Bottom Parts Location Detail

parts list

REFERENCE SYMBOL	MOTOROLA PART NO.	DESCRIPTION
C100	23-80319A67	capacitor, fixed: uF; 250 V; unless otherwise stated
C101	8-82096J04	1000 ± 3%; 35 V
C102	23-82601A23	.047
C103	21-832501	10 + 150-10%; 20 V
C104	21-865452	.01 + 60-40%
C105	21-832501	680 pF ± 10%; 500 V
C106,107	23-82601A23	.01 + 60-40%; 250 V
C108	21-840849	10 + 150-10%; 20 V
C109	21-868206	20 pF ± 5%; 500 V
C110	20-82399D05	10 pF ± 5%; 500 V
C111	21-832501	var. 9-35 pF
C112	21-865922	.01 + 60-40%
C113,114	21-865923	390 pF ± 10%; 500 V
C115 thru 118	21-832501	.001 ± 10%; 500 V
C119	8-82096J18	.01 + 60-40%
C120 thru 123	21-832501	0.1 ± 10%
C124	23-82601A23	.01 + 60-40%
C125	21-840713	10 + 150-10%; 20 V
C126	23-80319A67	120 pF ± 5%; 500 V
C127	8-82096J18	1000 ± 3%; 35 V
C128	23-82601A09	0.1 ± 10%
C129,130	21-832501	100 + 150-10%; 25 V
C131	21-865456	.01 + 60-40%
C132	21-82537B49	220 pF ± 3%
C133	21-832501	3900 pF ± 1%; 100 V
C134	21-863291	.01 + 60-40%
C135	21-832501	1500 pF ± 2%; 500 V
C137	21-848272	.01 + 60-40%
C138	8-82096J21	21 pF
C139	21-832501	.33 ± 10%
C140	8-82096J18	.01 + 60-40%
C141	8-82096J05	0.1 ± 10%
C142	21-832501	.068 ± 10%
CR100,101	48-82466H13	diode: (see note)
CR103 thru 106	48-82392B07	silicon
J100	28-80327A09	connector, receptacle: male, 10-contact
L100,101	24-80312A70	coil, rf: 100 mH
LS101	1-5951C88	transducer: speaker
Q100,101	48-869570	transistor: (see note)
Q103,104	48-869570	NPN; type M9570
Q105	48-869439	NPN; type M9570
Q106	48-869440	PNP; type M9439
Q107	48-869571	NPN; type M9440
Q108	48-869670	PNP; type M9571
Q109	48-869570	dual, NPN; type M9670
R101,102	6-124A73	NPN; type M9570
R103	6-124A65	resistor, fixed: ± 5%; 1/4 W; unless otherwise stated
R104	6-124A80	10k
R105	6-124A72	4.7k
R106	6-124B14	20k
R107	6-124A42	9.1k
R108	6-124A49	470k
R109,110	6-124A97	510
R111	6-124A73	1k
R112 thru 122	6-124A73	100k
R123	6-124A71	10k
R124	6-124A63	8.2k
R125	6-124A55	3.9k
R126	6-124A88	1.8k
R127	6-124A37	43k
R128,129	6-125A01	330
R130	6-124A73	10, 1/2 W
R131	6-124B10	10k
R132	6-124A67	330k
R133	6-124A73	5.6k
R134	6-80334A59	68.1k ± 1%
R135	6-80334A64	715k ± 1%
R136	6-124A67	5.6k
R137	6-124A73	10k
R138	6-80334A59	68.1k ± 1%
R139	6-80334A64	715k ± 1%
R140	6-124A67	5.6k
R141	6-124A73	10k
R142	6-80334A59	68.1k ± 1%
R143	6-80334A55	121k ± 1%
R144	6-80334A60	51.1k ± 1%
R145	6-80334A56	255k ± 1%
R146	6-80334A61	24.9k ± 1%
R147	6-80334A57	619k ± 1%
R148	6-80334A62	60.4k ± 1%
R149	6-80334A63	12.1k ± 1%
R150	6-80334A58	4.99k

PL-6443-O

REFERENCE SYMBOL	MOTOROLA PART NO.	DESCRIPTION
R151	6-124A49	1k
R152,153	18-80334A34	var. 10k
R154	6-124A93	68k
R155	6-124A91	56k
R156	6-124A82	24k
R157 thru 162	6-124A97	100k
R163	6-80334A64	715k ± 1%
R164	6-124A97	100k
R165	6-124A73	10k
R166	6-124A66	5.1k
R167	6-124B42	6.8 meg.
R168,169	6-124A61	3.3k
R170	6-124A49	1k
U101	51-80334A20	integrated circuit: (see note)
U102	51-80334A19	type MC3870
U103,104,105	51-8408D64	type MC14508
U106	51-82884L03	type MC7407
U107	51-82884L13	type MC14069
U108	51-84320A47	type MC14013
U109	51-84320A82	type MC7805
U110 thru 113	51-84887K17	type MC7815
U114,115,116	51-82884L49	type MC14527
U117	51-82884L52	type MC14070
U118	51-82884L12	type MC14052
U119	51-82884L07	type MC14518
U120	51-82884L03	type MC14520
U121	51-84320A93	type MC14069
U122	51-82884L28	type MC1455
U123	51-84887K60	type MC14528
U124	51-84621K21	type MC14053
U125,126	51-82884L52	type MC3403
U127	51-84320A13	type MC14052
X1	48-80334A35	crystal: 5.12 MHz
mechanical parts		
	9-80334A29	SOCKET, IC: 40-contact
	9-80330A49	SOCKET, IC: 16-contact
	7-80334A33	HEATSINK (U109)
	3-8022	SCREW, machine: 4-40 x 1/4"; 4 used
	4-80334A38	WASHER, nylon; 4 used
	4-83093J01	WASHER, insulator; 2 used
note: For optimum performance, diodes, transistors and integrated circuits must be ordered by Motorola part numbers.		

REFERENCE SYMBOL	MOTOROLA PART NO.	DESCRIPTION
A1	1-80304A02	display assembly: (see note)
A2	1-80304A03	includes: 48-84404E03 LED, red; 6 used
A3	1-80304A04	29-80334A28 TERMINAL, pin; 6 used
A4	1-80304A05	includes: 48-84404E03 LED, red; 2 used
C201	23-82601A23	includes: 48-84404E03 LED, red; 2 used
C202 thru 208	21-832501	29-80334A28 TERMINAL, pin; 6 used
J205	9-80334A43	capacitor, fixed: 10 uF + 150-10%; 20 V
Q201 thru 204	48-869571	.01 uF + 60-40%; 250 V
R201 thru 208	6-124A21	connector, receptacle: female, 13-contact
R210,211,212	6-124A45	transistor: (see note)
R213,214,215	6-124B67	PNP; type M9571
R216,217,218	6-124A97	resistor, fixed: ± 5%; 1/4 W;
R219	6-124A65	68
S200	40-80334A31	680 ohms
U201,202	51-84688D38	8.2
U203	51-82884L44	100k
U204	51-82884L35	4.7k
U205	51-82884L06	switch, toggle: spdt
U206 thru 212	48-80334A36	integrated circuit: (see note)
		type MC75492
		type MC14511
		type MC14017
		type MC14023
		7-segment display
mechanical parts		
	9-80336A32	SOCKET, IC: 10-contact; 7 used
	1-80307A71	CABLE, interconnect

PL-6444-O

REFERENCE SYMBOL	MOTOROLA PART NO.	DESCRIPTION
C300,301	8-82096J18	capacitor, fixed: .1 uF
C302,303	21-868717	.001 uF 2 kV ± 20%
CR300	48-82466H13	diode: (see note)
CR301	48-82256C53	silicon Zener, 18 V
E301,302	80-83029H02	spark gap: 230 V dc
F300	65-20987	fuse: .25A; 120 V
F301	65-898635	.75A; 32 V
J301	9-855268	connector, receptacle: BNC type
J302	28-80334A23	male, 2-contact
J303	9-80334A15	phono
L301,302	24-80312A70	coil, rf: 100 uH
P300		connector, plug: consists of: 15-80327A29 HOUSING, connector, 10-contact; 29-83499F01 TERMINAL, pin; 8 used
R300	17-812897	resistor: 50 ohm ± 10%; 5W, W.W.
S1	40-80334A32	switch, toggle: dpdt.
T300	25-80325A73	transformer: pri. no. 1 = leads A and B color coded BLK. pri. no. 2 = leads C coded BLU and D color coded BLU/WHT. sec. color coded RED w/center tap color coded RED/WHT
mechanical parts		
	1-80303A96	CHASSIS, riveted
	1-80307A97	ESCUTCHEON, keyboard
	4-80334A47	WASHER, insulator: 1/2 x .325-.030"
	4-80334A48	WASHER, insulator: 1/2 x .370-.070-.030"
	15-80336A30	COVER, high voltage
	42-80313A70	STRAP, tie
	43-80336A37	BUSHING, insulating
	29-5237	SOLDER LUG, BNC
	9-82083C01	FUSE HOLDER, 2 ea.
	54-83379A01	LABEL, high voltage

REFERENCE SYMBOL	MOTOROLA PART NO.	DESCRIPTION
C401	8-82096J21	capacitor, fixed: .33 pF ± 10%; 250 V
CR401,402	48-82466H13	diode: (see note)
U401	51-84320A82	silicon
integrated circuit: (see note)		
		type MC7815
mechanical parts		
	1-80304A01	BATTERY CASE, assembly includes: ref. item C401, CR401, 402, U401
	1-80303A99	BATTERY CASE, riveted
	3-7178	SCREW, machine: 6-32 x 5/16"
	4-7650	WASHER, lock
	29-80336A34	TERMINAL, receptacle; 4 used
	42-82143C01	CLAMP
	3-8022	SCREW, machine: 4-40 x 1/4"
	4-7607	WASHER, flat
	1-80303A98	BATTERY COVER, assembly includes:
	15-80336A29	COVER, battery housing
	3-7178	SCREW, machine: 6-32 x 5/16"; 4 used
	4-80334A39	WASHER, nylon; 4 used
	4-7650	WASHER, lock; 4 used

PL-6442-O

PL-6441-O

APPENDIX

INTRODUCTION

Many of the signaling tones and codes used in radio communications have become standard. These commonly used tones and codes are listed in this Appendix for easy reference when servicing tone or code controlled systems.

Table 1. Two-Tone Paging Tones

TONE NUMBER	TONE GROUP 1		TONE GROUP 2		TONE GROUP 3		TONE GROUP 4		TONE GROUP 5		TONE GROUP 6	
	FILTER CODE	FREQ. (Hz)	FILTER CODE	FREQ. (Hz)	FILTER CODE	FREQ. (Hz)	FILTER CODE	FREQ. (Hz)	FILTER CODE	FREQ. (Hz)	FILTER CODE	FREQ. (Hz)
1	111	349.0	121	600.9	138	288.5	141	339.6	151	584.8	191	1153.4
2	112	368.5	122	634.5	108	296.5	142	358.6	152	617.4	192	1185.2
3	113	389.0	123	669.9	139	304.7	143	378.6	153	651.9	193	1217.8
4	114	410.8	124	707.3	109	313.0	144	399.8	154	688.3	194	1251.4
5	115	433.7	125	746.8	160	953.7	145	422.1	155	726.8	195	1285.8
6	116	457.9	126	788.5	130	979.9	146	445.7	156	767.4	196	1321.2
7	117	483.5	127	832.5	161	1006.9	147	470.5	157	810.2	197	1357.6
8	118	510.5	128	879.0	131	1034.7	148	496.8	158	855.5	198	1395.0
9	119	539.0	129	928.1	162	1063.2	149	524.6	159	903.2	199	1433.4
0	110	330.5	120	569.1	189	1092.4	140	321.7	150	553.9	190	1122.5

Table 2. Common PL Tones

CODE	FREQUENCY (Hz)	CODE	FREQUENCY (Hz)
XZ	67.0	4	136.5
XA	71.9	4A	141.3
XB	77.0	4B	146.2
YZ	82.5	5Z	151.4
YA	85.4	5A	156.7
YB	88.5	5B	162.2
ZZ	91.5	6Z	167.9
ZA	94.8	6A	173.8
ZB	97.4	6B	178.9
1Z	100.0	7Z	186.2
1A	103.5	7A	192.8
1B	107.2	8Z	206.5
2Z	110.9	M1	203.5
2A	114.8	M2	210.7
2B	118.8	M3	218.1
3Z	123.0	M7	256.3
3A	127.4	M4	225.7
3B	131.8	9Z	229.2

Table 3. Common Subaudible Tones

TONE	TONE GROUP 7		TONE GROUP 8		TONE GROUP 9	
	CODE	FREQ. Hz	CODE	FREQ. Hz	CODE	FREQ. Hz
1	101	202.7	4A	141.3	1Z	100.0
2	7A	192.8	4Z	136.5	WB	79.7
3	7Z	186.2	3B	131.8	ZA	94.8
4	6B	179.9	3A	127.3	ZZ	91.5
5	6A	173.8	3Z	123.0	YB	88.5
6	6Z	167.9	2B	118.8	YA	85.4
7	5B	162.2	2A	114.8	YZ	82.5
8	5A	156.7	2Z	110.9	XB	77.0
9	5Z	151.4	1B	107.2	XA	71.9
0	4B	146.2	1A	103.5	XZ	67.0

TONE	TONE GROUP 17		TONE GROUP 18		TONE GROUP 9	
	CODE	FREQ. Hz	CODE	FREQ. Hz	CODE	FREQ. Hz
1	101	202.7	4A	141.3	1Z	100.0
2	7A	192.8	4Z	136.5	WB	79.7
3	7Z	186.2	3B	131.8	ZA	94.8
4	WZ	69.3	3A	127.3	ZZ	91.5
5	6A	173.8	3Z	123.0	YB	88.5
6	6Z	167.9	WA	74.4	YA	85.4
7	5B	162.2	2A	114.8	YZ	82.5
8	5A	156.7	2Z	110.9	XB	77.0
9	5Z	151.4	1B	107.2	XA	71.9
0	4B	146.2	1A	103.5	XZ	67.0

Table 4. Authorized DPL Codes

**Available
from
factory**

Table 5. Tone Remote Control Standard Function Tone Frequencies

Frequency (Hz)	Function
2175	Guard Tone
2050	“Private-Line” Disable
1950	Transmit F1
1850	Transmit F2
1750	R2 Mute or (Receive F1)
1650	R2 Unmute or (Receive F2)
1550	“MAX” SQUELCH or REPEATER “OFF” or “PL” ON
1450	“MIN” SQUELCH or REPEATER “ON” or “PL” OFF
1350	“Wild Card” I ON
1250	“Wild Card” I OFF
1150	“Wild Card” II ON
1050	“Wild Card” II OFF

Table 6. IMTS Frequencies

Frequency (Hz)	Function
2000	Idle Tone
1800	Seize Tone
1336	Disconnect Tone
1633	Connect Tone
2150	Guard Tone

SAFE HANDLING OF CMOS INTEGRATED CIRCUIT DEVICES

Many of the integrated circuit devices used in communications equipment are of the CMOS (Complementary Metal Oxide Semiconductor) type. Because of their high open circuit impedance, CMOS ICs are vulnerable to damage from static charges. Care must be taken in handling, shipping, and servicing them and the assemblies in which they are used.

Even though protection devices are provided in CMOS IC inputs, the protection is effective only against overvoltage in the hundreds of volts range such as are encountered in an operating system. In a system, circuit elements distribute static charges and load the CMOS circuits, decreasing the chance of damage. *However, CMOS circuits can be damaged by improper handling of the modules even in a system.*

To avoid damage to circuits, observe the following handling, shipping, and servicing precautions.

1. Prior to and while servicing a circuit module, particularly after moving within the service area, momentarily touch *both* hands to a bare metal earth grounded surface. This will discharge any static charge which may have accumulated on the person doing the servicing.

NOTE

Wearing Conductive Wrist Strap (Motorola No. RSX-4015A) will minimize static buildup during servicing.

2. Whenever possible, avoid touching any electrically conductive parts of the circuit module with your hands.

3. Normally, circuit modules can be inserted or removed with power applied to the unit. However,

check the INSTALLATION and MAINTENANCE sections of the manual as well as the module schematic diagram to insure there are no objections to this practice.

4. When servicing a circuit module, avoid carpeted areas, dry environments, and certain types of clothing (silk, nylon, etc.) because they contribute to static buildup.

5. All electrically powered test equipment should be grounded. *Apply* the *ground lead* from the test equipment to the circuit module *before* connecting the *test probe*. Similarly, *disconnect* the *test probe* prior to removing the *ground lead*.

6. If a circuit module is removed from the system, it is desirable to lay it on a conductive surface (such as a sheet of aluminum foil) which is connected to ground through 100k of resistance.

WARNING

If the aluminum foil is connected directly to ground, be cautious of possible electrical shock from contacting the foil at the same time as other electrical circuits.

7. When soldering, be sure the soldering iron is grounded.

8. Prior to connecting jumpers, replacing circuit components, or touching CMOS pins (if this becomes necessary in the replacement of an integrated circuit device), be sure to discharge any static buildup as described in procedure 1. Since voltage differences can exist across the human body, it is recommended that only one hand be used if it is necessary to touch pins on the CMOS device and associated board wiring.



9. When replacing a CMOS integrated circuit device, leave the device in its metal rail container or conductive foam until it is to be inserted into the printed circuit module.

10. All low impedance test equipment (such as pulse generators, etc.) should be connected to CMOS device inputs after power is applied to the CMOS cir-

cuitry. Similarly, such low impedance equipment should be disconnected before power is turned off.

11. Replacement modules shipped separately from the factory will be packaged in a conductive material. Any modules being transported from one area to another should be wrapped in a similar material (aluminum foil may be used). NEVER USE NON-CONDUCTIVE MATERIAL for packaging these modules.